



The HUB Module Signaling System & Signaling Project Update



HUB RailFun

June 17, 2020

a presentation by

Erich Whitney



6/24/20



Introduction: Erich Whitney



-
- Engineering Manager at The MITRE Corporation in Bedford, MA
 - Lives in Derry, NH
 - Bachelors & Masters in Electrical & Computer Engineering, UNH
 - Masters in Systems Engineering , WPI
 - Black Cat Model Railroad (BCRR)
 - Currently in design, pending basement renovation project
 - NMRA Member since 2009
 - Member of HUB Modular RR Group, OPSIG, LDSIG, CMRISIG
 - Recently transitioned to the HUB Division
 - Current member of the DCC Working Group, Conformance and Inspection Committee, working on reviving the NMRA's DCC Command Station Conformance Testing Program
 - Past president of the Seacoast Division NMRA
 - Chairman of the 2013 NER NMRA Convention in Laconia
 - Former Youth in Model Railroading parent





Overview



-
- I. Review and background on the HUB Module Group's Signaling Project from Dick Johannes

 - II. Where are we now?

 - III. Introduction of the HUB Modular Signaling Testbed

 - IV. Summary, Discussion, Important Reference Material
 - At the end of this slide deck



Dedication

This presentation is dedicated to our dear friend,
Richard “Doc” Johannes, July 12, 2017



and...



Dedication



And to Chuck Catania, January 4, 2019
(Model Railroad Control Systems)

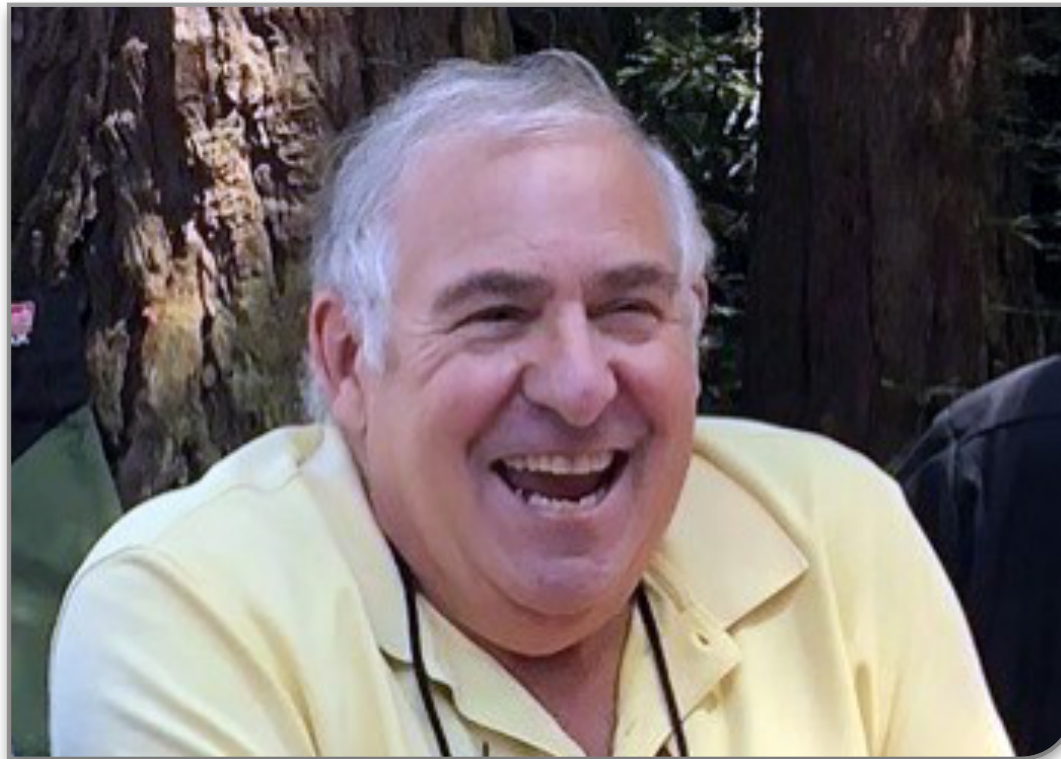



Section I



Review and background on the HUB Module Group's Signaling Project from Dick Johannes



Implementing Modular Layout Signaling Operations with CMRI & CATS

Dick Johannes
& the HUB Division Signal Committee
presented by Erich Whitney

*Part of this presentation has been given at NMRA
National Conventions: KSC2018 and SLC2019*





You Can Learn a Lot in 8 sq ft



- At the outset we had (circa 2012?):
 - 5 bus wiring harness supports 2 mainlines buses, a local track bus, an accessory DCC bus, and an 18 volt AC accessory bus
 - 2 Cat5 buses: XpressNet bus & a 2nd unused
- Replete with high-end craftsman structures and scratch-built structures
- Numerous experiments with scenic techniques
- Remember, the overarching goal is to serve our members
- Why not Signaling next??



Home Layout Plan

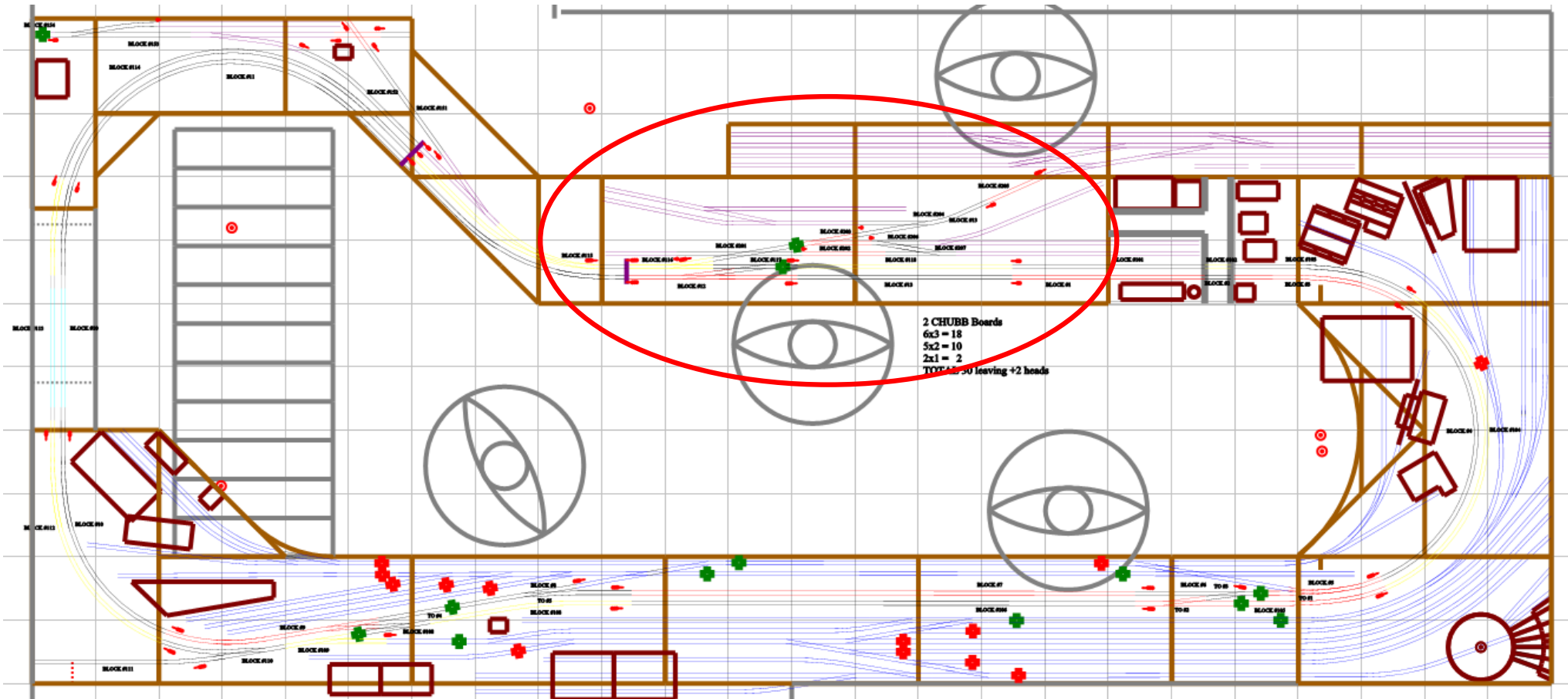



Goals & Rationale



- Increase the knowledge and curiosity in signaling within HUB Division members
- Add a new level of operating interest to the modular layout
- Enhance the viewing experience for spectators of the layout
- Sounded like fun!!



Key historical events in railroad signaling



- 1840: Ball signals: LTC Rolt
- 1841: Semaphore – Charles Gregory
- 1851: Telegraph – Chas Minot
- 1870: Track Circuit – William Robinson
- 1871: Disk (Banjo) Signal – Thomas Hall
- 1904: Color light signals – William Churchill
- 1915: Position-light signals – Arthur Rudd
- 1920: Searchlight Signals – Hall Signal Co.
- 1924: Color Position signals – Frank Patenall
- 1925: Tri-color (G type) signals - GRS



Two types of “regions”

Interlockings (Junctions & Sidings)

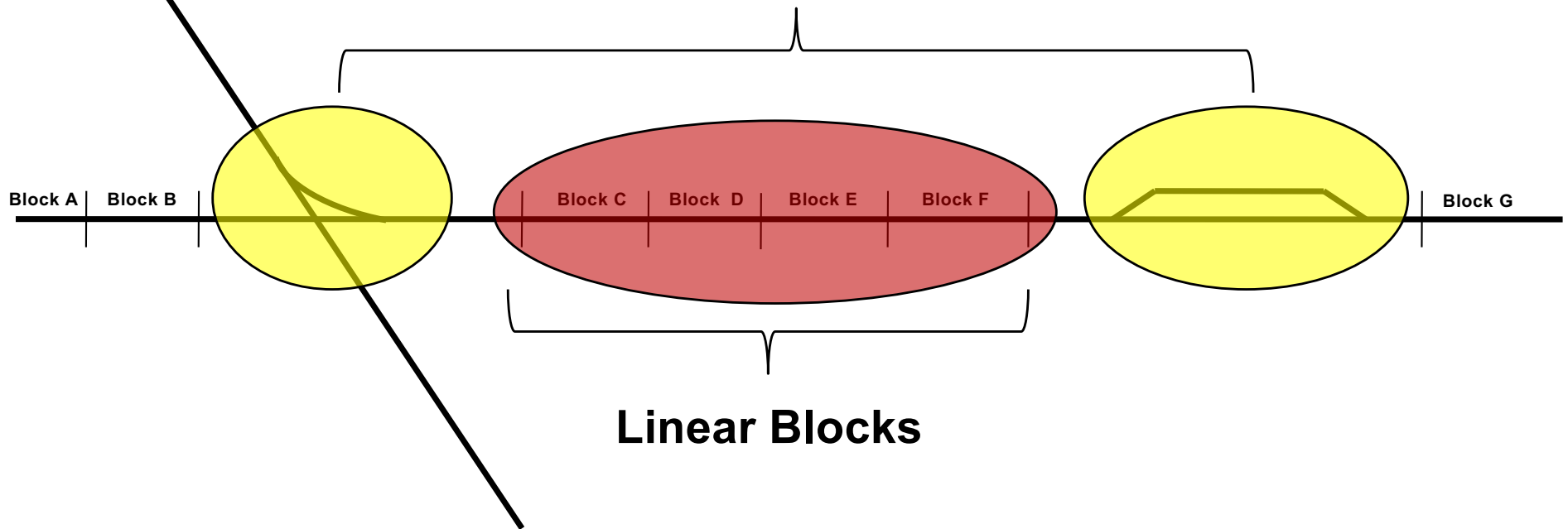











The Distinctions

- Linear blocks
 - Unsupervised (e.g. totally automated)
 - Default is “clear” or “green”
 - ABS (Automatic Block Signaling)
 - APB (Absolute Permissive Block)
 - Space trains
- Interlockings (Junctions & Sidings)
 - Human operated (e.g. human controlled)
 - Default is “stop” or “red”
 - Mechanical interlocks
 - US&S panels & Computerized CTC
 - Allow train movement



Aspect Combinatorics & (NORAC)



UPPER HEAD	LOWER HEAD	Signal	RULE (Aspect)
GREEN	GREEN		281
GREEN	YELLOW		Not Used
GREEN	RED		281
YELLOW	GREEN		282
YELLOW	YELLOW		284
YELLOW	RED		285
RED	GREEN		283
RED	YELLOW		290
RED	RED		291



Aspects: NORAC*

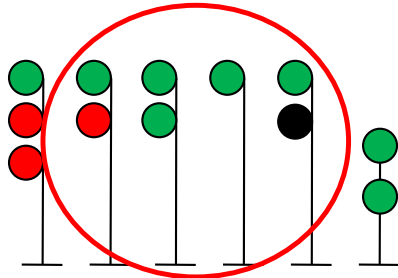

Rule: 281
Name: Clear
Indication: Proceed not exceeding Normal Speed

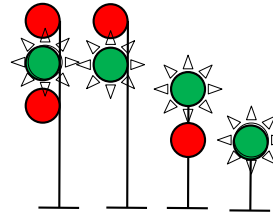

Rule: 281c
Name: Limited Clear
Indication: Proceed at Limited Speed until entire train clears all interlocking or spring switches

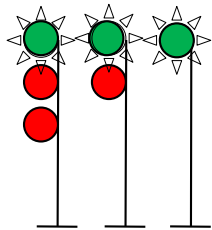

Rule: 281a
Name: Cab Speed
Indication: Proceed in accordance with cab signal indication

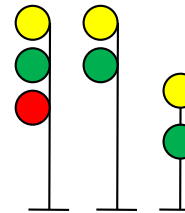

Rule: 282
Name: Approach Medium
Indication: Proceed approaching the next signal at Medium Speed

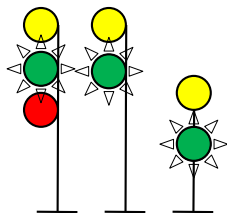

Rule: 281b
Name: Approach Limited
Indication: Proceed approaching the next signal at Limited Speed

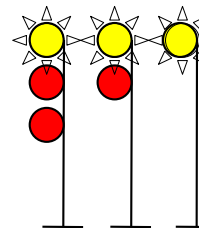

Rule: 282a
Name: Advance Approach
Indication: Proceed prepared to stop at the second signal. Trains exceeding Limited Speed must reduce to Limited Speed as engine passed the signal



Aspects: NORAC* (cont)

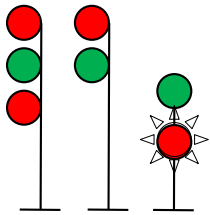

Rule: 283
Name: Medium-Clear
Indication: Proceed at Medium Speed until entire train clears all interlocking or spring switches, then proceed at Normal Speed

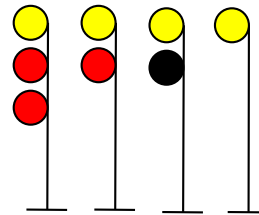

Rule: 285
Name: Approach
Indication: Proceed prepared to stop at the next signal. Reduce to Medium Speed as engine passes signal

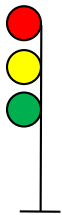

Rule: 283a
Name: Medium Approach Medium
Indication: Proceed at Medium Speed until entire train clears all interlocking or spring switches, then approach next signal at Medium Speed

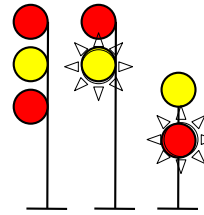

Rule: 286
Name: Medium Approach
Indication: Proceed prepared to stop at the next signal. Reduce to Medium Speed as soon as signal is clearly visible

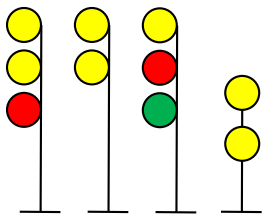

Rule: 284
Name: Approach Slow
Indication: Proceed approaching the next signal at Slow Speed

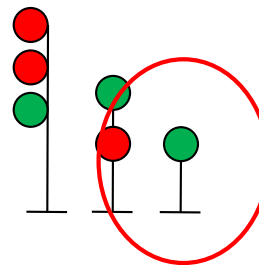

Rule: 287
Name: Slow Clear
Indication: Proceed at Slow Speed until entire train clears all interlocking or spring switches, then proceed at Normal Speed



Aspects: NORAC* (cont)

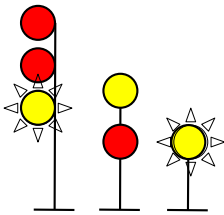

Rule: 288
Name: Slow Approach
Indication: Proceed at Slow Speed until entire train clears all interlocking or spring switches, then proceed at Medium Speed

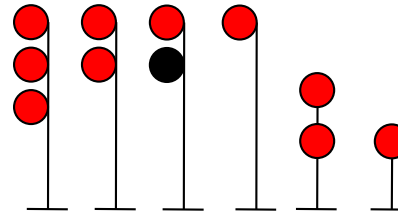

Rule: 292
Name: Stop Signal
Indication: Stop

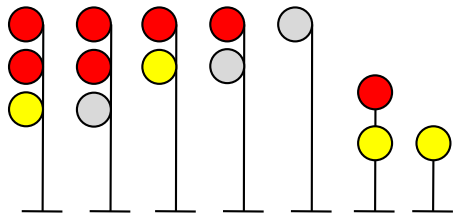

Rule: 290
Name: Restricting
Indication: Proceed at Restricted Speed until entire train clears all interlocking or spring switches and leading wheels have 1) passed a more favorable signal or 2) entered non-signal territory.

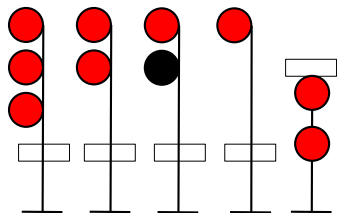

Rule: 291
Name: Stop and Proceed
Indication: Stop then proceed at Restricted Speed until leading wheels have 1) passed a more favorable signal or 2) entered non-signal territory

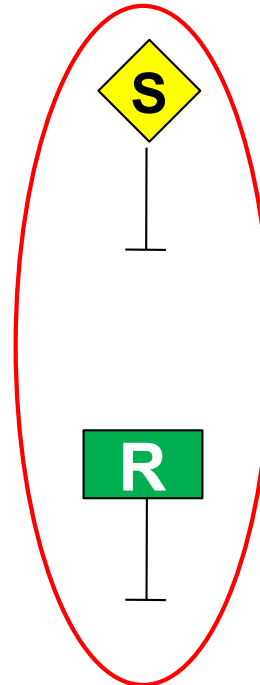

Rule: 296b
Name: Speed Limit Sign
Indication: Proceed at speed posted on the Approach Speed Limit Sign until entire train has passed the Resume Speed Sign

Rule: 296c
Name: Resume Speed Sign
Indication: Resume speed after entire train has passed the Resume Speed Sign

* 9th Edition, 2008



- Flashing



The 4 Rules for Modular Operation



1. If all the signal heads show red – **STOP**
2. If a signal shows green on the top head – **GO**
(Track Speed)
3. If any signal head shows a yellow lamp or shows green on the lower heads – **GO SLOW**
4. If the bottom lamp is Yellow and all lamps above it are red – Operate at **RESTRICTED** speed (15 mph or ½ visual distance)



Locks



-
- **Route Locking:** Prevents realigning a turnout while a selected route is occupied.
 - **Indication Locking:** Prevents realigning a turnout or clearing a conflicting signal when a signal for entry into the route has been cleared.
 - **Time Locking:** Prevents realigning a turnout or clearing a conflicting signal for a period of time after the dispatcher has “knocked down” a cleared signal.



Advice We Were Given



-
- Pay attention to modeling details just as you would in any other aspect of model railroading
 - Separate the signaling bus from train control
 - Solve occupancy then move to signals
 - You won't regret using either C/MRI or Digitrax
 - Largely, we took this advice but made some compromises



Frame the Issues

- This is a classical data processing issue
 1. What are the inputs and where do they come from?
 2. How do we process the incoming data transforming it into information?
 3. How do we output the processed information?
- We were looking for a hardware AND a software solution



Complexity of Hardware

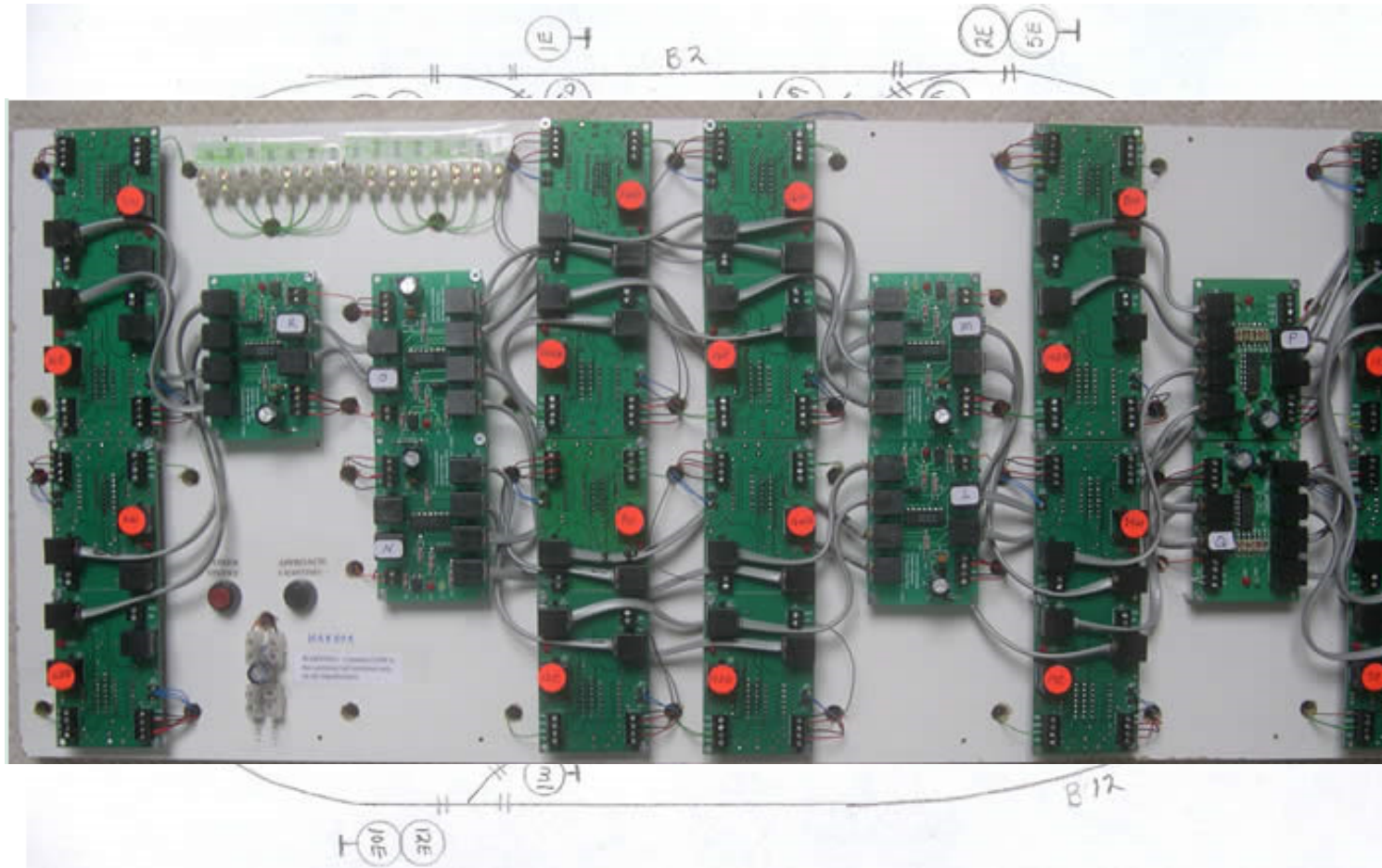



Experiment, Experiment, Experiment



- We adopted JMRI early
 - Broad support for multivendor solutions
 - Already had experience with DecoderPro & WiThrottle
 - We got to the point where we could build US&S style panel using PanelPro.
 - JMRI website
 - Dick Bronson's NMRA online clinics





US&S CTC Panels

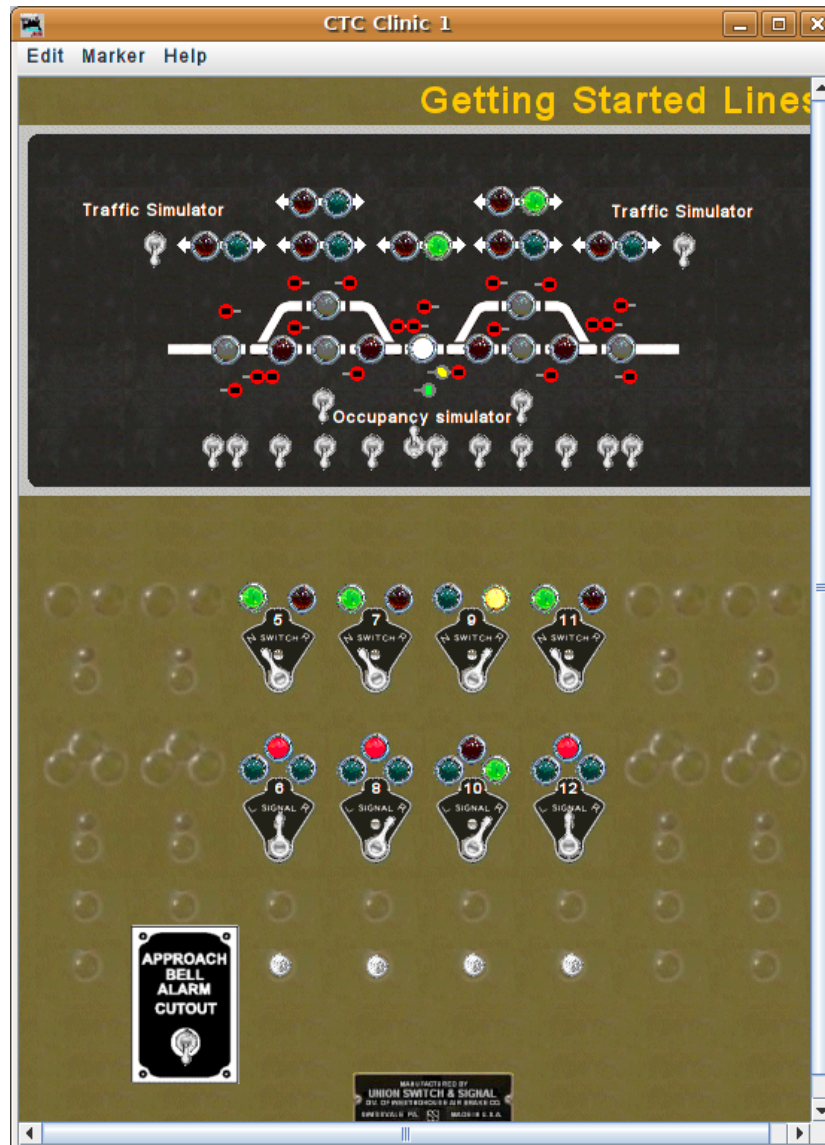

Screen shot from
Dick Bronson's
Hartford National
Clinics
Using
PanelPro



6/24/20



But There Was Interest in a Modern CRT-based Panel



- We looked at the Layout Editor
- Using the JMRI Website, we found CATS (Computer Automated Traffic System)
- Open Source JAVA software layered atop PanelPro
- Written by Rodney Black. Like JMRI, it has an online user forum
- Based upon prototype Digicon system



Direct Comparison

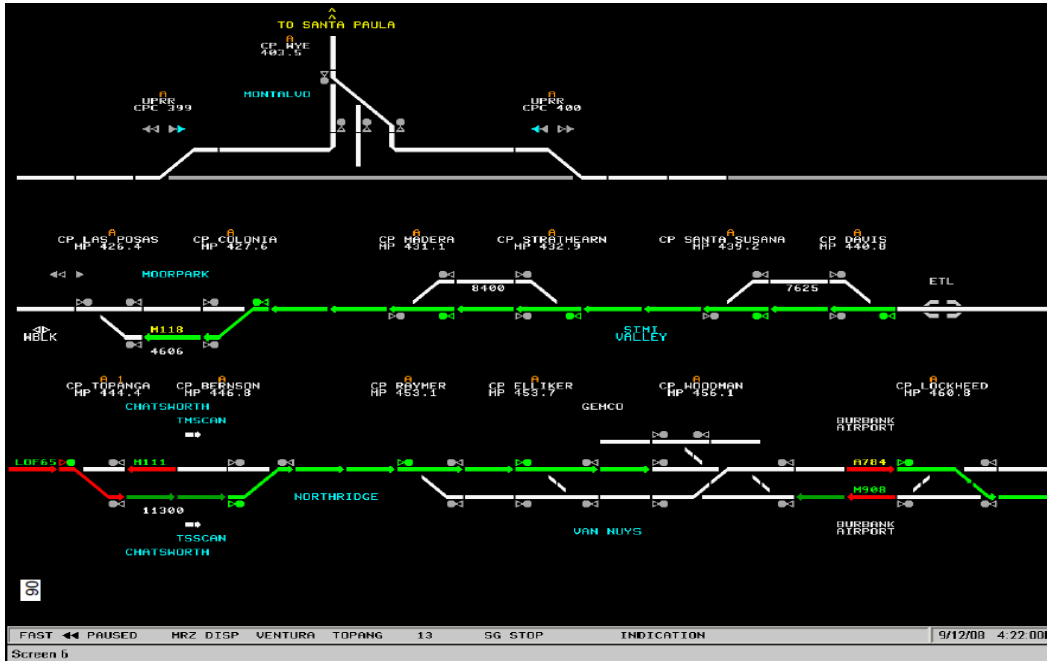

Screenshot of the Digicon Prototype

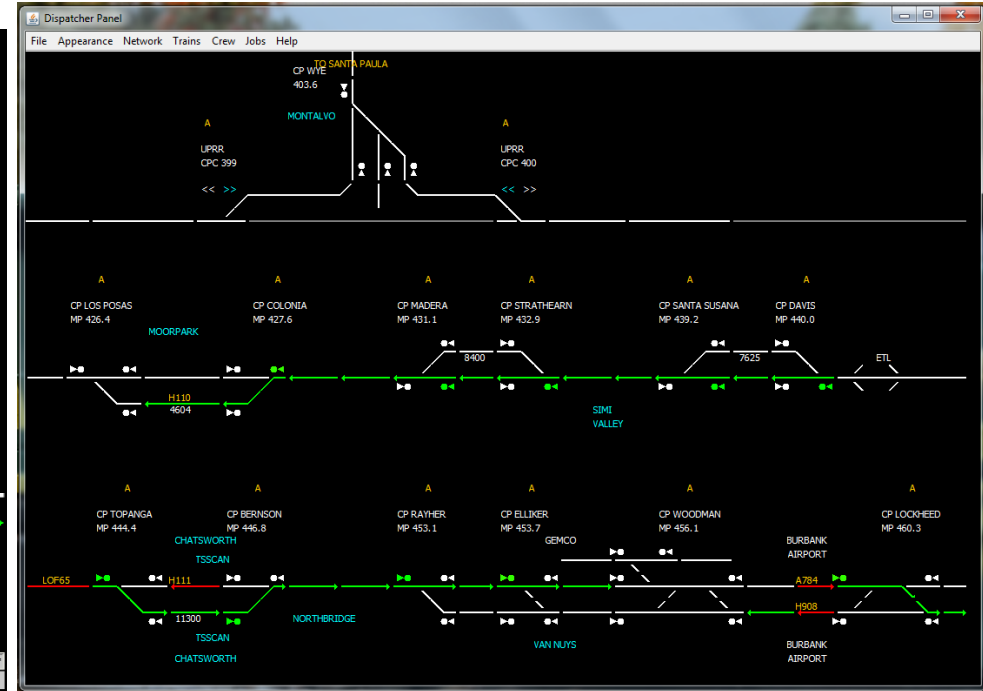

CATS Rendering of the Prototype





CATS Screen Shot

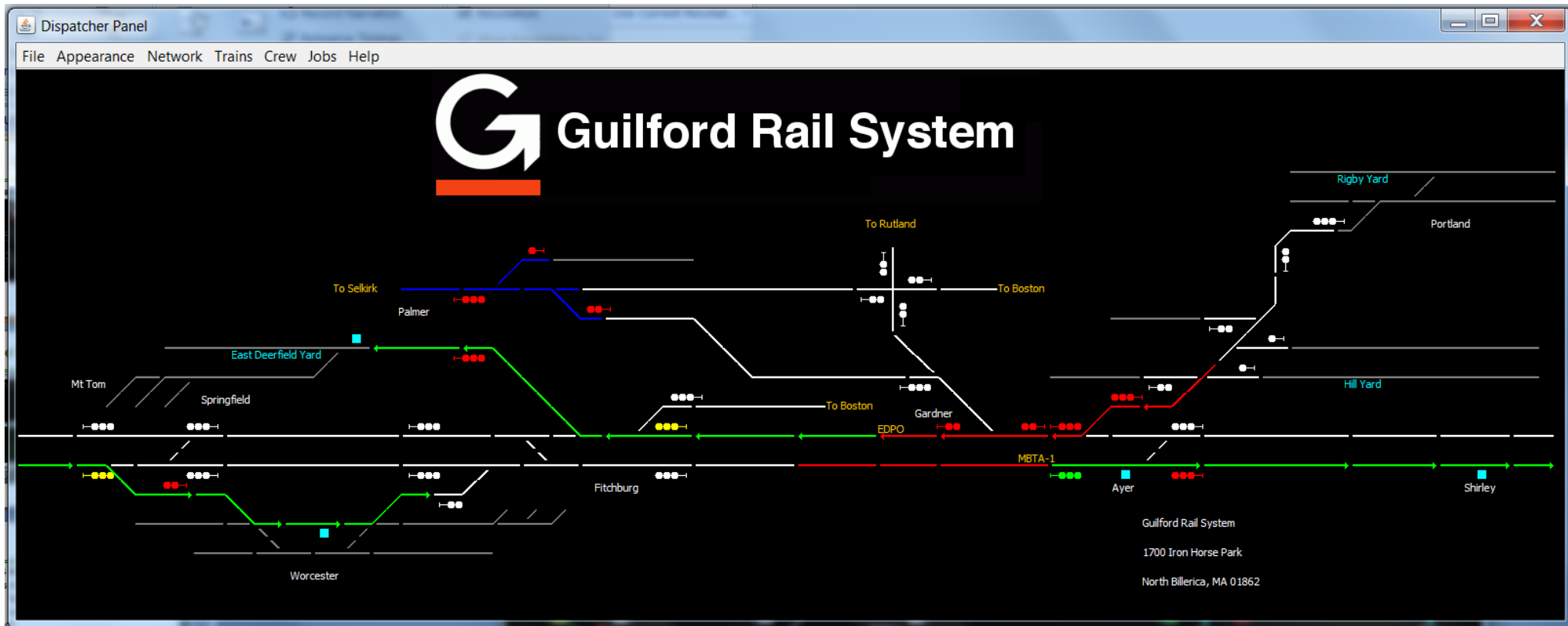

6/24/20



CATS



-
- Several outstanding features
 - Uses all the debugging tools in JMRI
 - Great benefits even without signals
 - Signaling based on 4 track speed / 2 or 3 block rules
 - “Pre-programmed” signal logic
 - CTC signals are visible whereas intermediate signals are not visible on the dispatcher panel
 - Can grant track authority
 - Can take track out of service
 - Allows train tracking by train symbol or locomotive #
 - Well written online manuals



CATS Suite is 3 Programs



-
- DESIGNER
 - Used to describe the panel (e.g. track, turnouts & signals)
 - Creates a permanent stored XML file
 - Detector and signal definitions & address mapping
 - Many display options
 - CATS
 - The runtime application
 - Many runtime controls and display options
 - TRAINSTAT
 - Tool to allow documenting train location and time (either real time or fast clock)
 - Can be stored to file for archiving



The Signal Template (Defaults)



Signal Aspect Template

Next Speed

Normal Limited Medium Slow Advance Halt

	ARA 281	ARA 281B	ARA 282	ARA 284	Adv Normal	ARA 285
Normal	green red	green red	yellow yellow	yellow yellow	yellow yellow	yellow red
Protected Limited	ARA 281C green red	CROR 412 green red	CROR 413 yellow yellow	CROR 414 yellow yellow	Adv Limited yellow yellow	ARA 281D yellow red
	ARA 283 red green	CROR 417 red green	ARA 283A red green	ARA 283B red green	Adv Medium red green	ARA 286 red yellow
Medium						
Slow	ARA 287 red green	CROR 422 red green	CROR 423 red green	CROR 424 red green	Adv Slow red green	ARA 288 red yellow

Restricting ARA 290
red
red

Halt ARA 292
red
red

Stop & Proceed ARA 291
red
red

Approach Lighting

Accept Cancel



Define Your Signal Rules

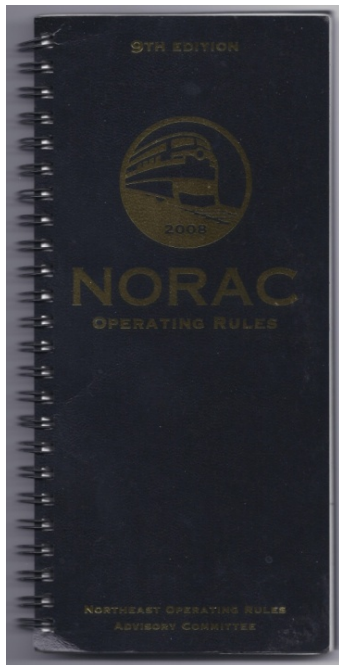

Rule	Aspect	Name	Indication
281b		APPROACH LIMITED	Proceed approaching the next signal at Limited Speed.
281c		LIMITED CLEAR	<p>Proceed at Limited Speed until entire train clears all interlocking or spring switches, then proceed at Normal Speed.</p> <p>In CSS territory with fixed automatic block signals, trains not equipped with operative cab signals must approach the next signal at Limited Speed.</p>
282		APPROACH MEDIUM	Proceed approaching the next signal at Medium Speed.

Rule	Aspect	Name	Indication
288		SLOW APPROACH	Proceed prepared to stop at next signal. Slow Speed applies until entire train clears all interlocking or spring switches, then Medium Speed applies.
290		RESTRICTING	<p>Proceed at Restricted Speed until the entire train has cleared all interlocking and spring switches (if signal is an interlocking or CP Signal) and the leading wheels have:</p> <ol style="list-style-type: none"> 1. Passed a more favorable fixed signal. or 2. Entered non-signalized DCS territory. <p>In CSS territory, trains with operative cab signals must not increase speed until the train has run one train length or 500 feet (whichever distance is greater), past a location where a more favorable cab signal was received.</p>



The Signal Template (HUB Edited)



Signal Aspect Template

Next Speed

	Normal	Limited	Medium	Slow	<input type="checkbox"/> Advance	Halt
Normal	ARA 281 green red	ARA 281B green red	ARA 282 yellow yellow	ARA 284 yellow yellow	Adv Normal yellow yellow	ARA 285 yellow red
	ARA 281C red flashing green	CROR 412 green red	CROR 413 yellow yellow	CROR 414 yellow yellow	Adv Limited yellow yellow	ARA 281D yellow red
Protected Medium	ARA 283 red green	CROR 417 red green	ARA 283A red green	ARA 283B red green	Adv Medium red green	ARA 286 red yellow
	ARA 287 red green	CROR 422 red green	CROR 423 red green	CROR 424 red green	Adv Slow red green	ARA 288 red yellow
Restricting	ARA 290 red yellow	Halt	ARA 292 red red	Stop & Proceed	ARA 291 red red	<input type="checkbox"/> Approach Lighting

Accept Cancel



The Testing Environment

2. CATS Runtime

4. JMRI Signal Head Table

Sy...	User Name	State	Comment	Delete	Lit	Hold
CATS:...	Sig1-UpperHead	Red		<input checked="" type="checkbox"/>	<input type="checkbox"/>	<input type="checkbox"/>
CATS:...	Sig1 - Middle Head	Yellow		<input checked="" type="checkbox"/>	<input type="checkbox"/>	<input type="checkbox"/>
CATS:...	Sig1 - Lower Head	Red		<input checked="" type="checkbox"/>	<input type="checkbox"/>	<input type="checkbox"/>

3. JMRI Sensor Table

Sy...	User Name	State	Comment	In...	Use Global ...	Active Delay	InActive De...
CS1001		Inactive		<input type="checkbox"/>	<input type="checkbox"/>	0	0
CS1002		Inactive		<input type="checkbox"/>	<input type="checkbox"/>	0	0
CS1003		Inactive		<input type="checkbox"/>	<input type="checkbox"/>	0	0
CS1004		Inactive		<input type="checkbox"/>	<input type="checkbox"/>	0	0
CS1005		Inactive		<input type="checkbox"/>	<input type="checkbox"/>	0	0
CS1006		Inactive		<input type="checkbox"/>	<input type="checkbox"/>	0	0
CS1007		Inactive		<input type="checkbox"/>	<input type="checkbox"/>	0	0
CS1008		Inactive		<input type="checkbox"/>	<input type="checkbox"/>	0	0
CS1009		Inactive		<input type="checkbox"/>	<input type="checkbox"/>	0	0
CS1010		Active		<input type="checkbox"/>	<input type="checkbox"/>	0	0
CS1011		Inactive		<input type="checkbox"/>	<input type="checkbox"/>	0	0
CS1013		Inactive		<input type="checkbox"/>	<input type="checkbox"/>	0	0
ISCL0...		Active		<input type="checkbox"/>	<input type="checkbox"/>	0	0

5. The System Monitor

```
2437 nce.NceConnectionStatus INFO - NCE EPROM revision = 6.2.1 [AWT-EventQueue-0]
3385 apps.Crandic INFO - main initialization done [main]
size=java.awt.Rectangle[x=0,y=0,width=656,height=461]
12046 jmri.SWS.mailHead WARN - SignalHead Sig1 - Middle Head is missing the Upcoder definition
for off [AWT-EventQueue-0]
19386 audio.NullAudioFactory INFO - Null audio sounds will be available.
[AWT-EventQueue-0]
Signal #1 head 1 indication is ARA 285 - Approach color is yellow
Signal #1 head 2 indication is ARA 285 - Approach color is red
Signal #1 head 3 indication is ARA 285 - Approach color is red
Signal #1 head 1 indication is ARA 281B - Normal Approach Limited color is flashing green
Signal #1 head 2 indication is ARA 281B - Normal Approach Limited color is red
Signal #1 head 1 indication is ARA 283 - Medium Clear color is red
Signal #1 head 2 indication is ARA 283 - Medium Clear color is green
Signal #1 head 3 indication is ARA 283 - Medium Clear color is red
Signal #1 head 1 indication is ARA 286 - Medium Approach color is red
Signal #1 head 2 indication is ARA 286 - Medium Approach color is yellow
Signal #1 head 3 indication is ARA 286 - Medium Approach color is red
```

1. JMRI (simulator)

CTC Panel
Generic Dispatcher Panel, based on JMRI 3.2+21862
http://home.comcast.net/~kb0oys
XPressnet: using XPressNet Simulator on (none)
C/MRI: using Simulator on (none)
NCE: using Simulator on (none)





The Difficult Requirements



- Modular specification forbids circuitry in-line with the DCC signal
- Minimal (if any) changes to existing modules if the builder choose not to add signals
- Cost
- Railroad can operate even if the signals don't
- **Must be able to shuffle modules in any order at each setup and signaling must work with no wiring changes and minimal setup effort**



Arbitrary Module Order

- How does one swap module order and preserve signal logic?
- The File → Import function
 - File->Import reads in a saved layout (a library) without erasing any existing work. It is a way to merge multiple layouts together, add some pre-canned design elements to the existing layout, insert existing signal definitions, etc. When a file is selected, designer will grab the track plan from the file and insert the upper grid corner of the trackplan at the grid cursor location. It will expand the layout in the horizontal and vertical directions as needed. Note that the library is not inserted, but replaces existing track; thus, preserving any track not overlaid
 - Tracks, information associated with tracks (e.g. Block definitions), Stations, Signals, etc. will be added to the existing work. File->Import will also merge any Devices (Section 8) defined in the file, but not any Appearances (Section 14.1), Trains (Section 10), Crew (Section 12), or Jobs (Section 11). **“Merging” is defined as “if something in the file does not exist in the current trackplan, it is added”.** This means that things in the library file will not replace things with the same name in the trackplan.



We Built 5 “*Test*” Modules

-
- Two were “**passive**” (e.g. do not have a signaling card)
 - No detection
 - No signals
 - These represented unchanged modules
 - Three were “**active**” modules (e.g. have a signaling card)
 - These 3 modules all contained signals
 - Each module used a different type of signal
 - 1 used G-type, 1 used Searchlight, 1 used D-type
 - All wired as common anode
 - NCE AIU & BD20s used for detection, Oaktree signal boards
 - Wiring strategy:
 - Inner main supplies power & detection to the left
 - Outer main supplies power & detection to the right



Signals in 90 Minutes

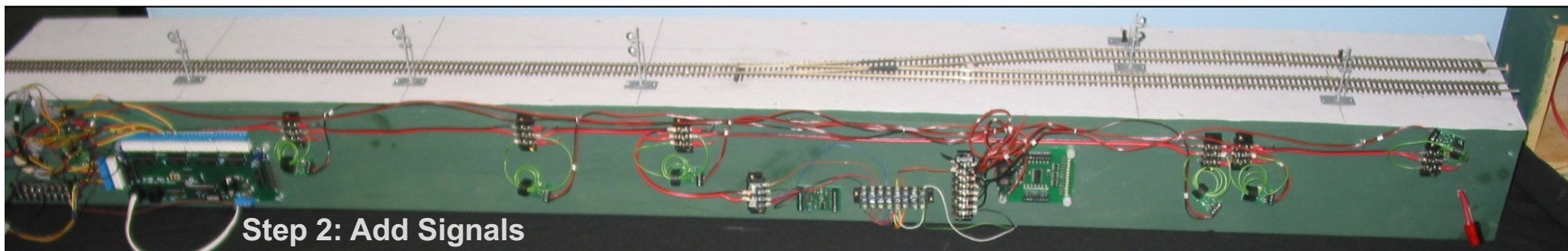
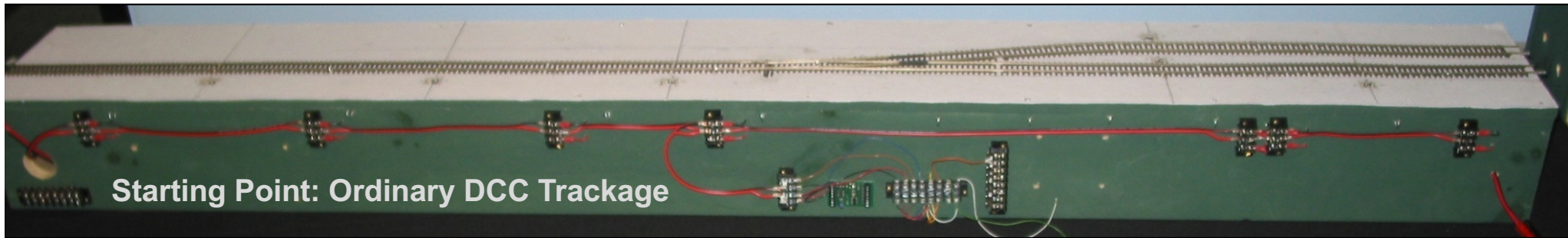



The Test Modules

Three "Active Modules"

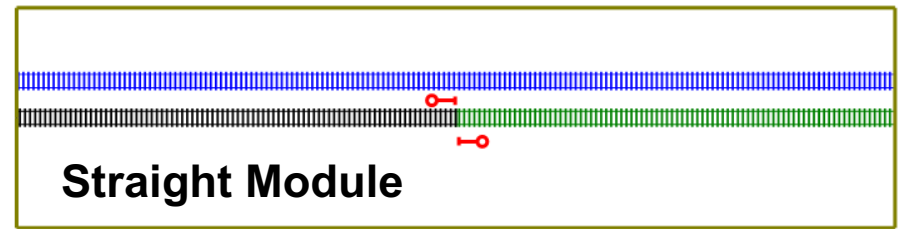
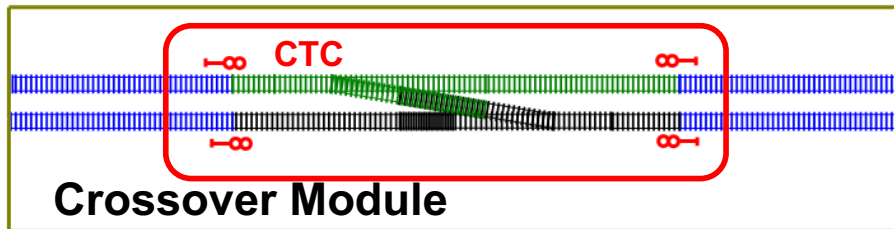
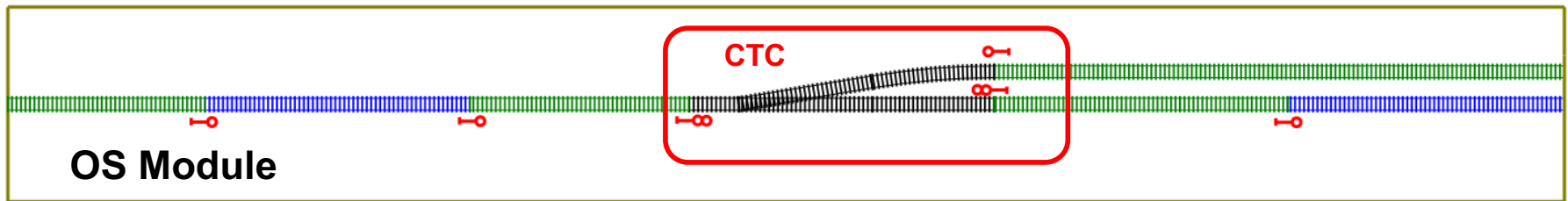

Two "Passive" Modules

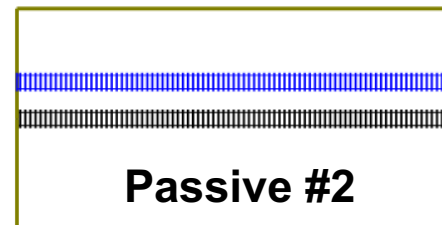
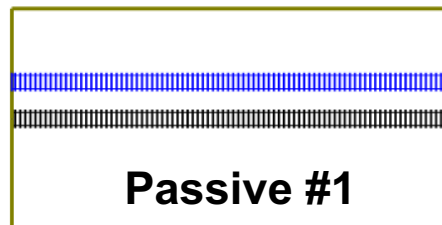



The Six Permutations

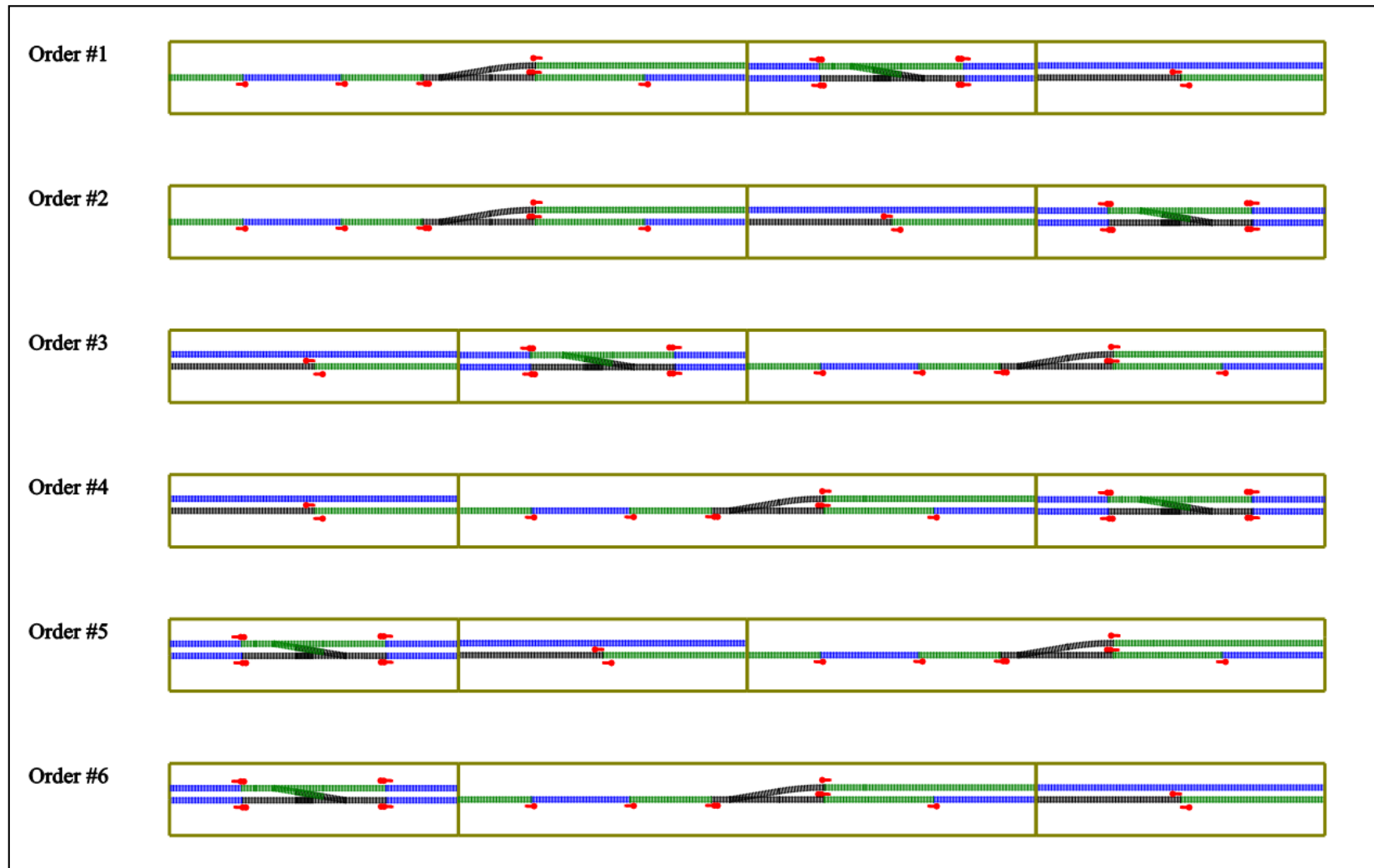



Permutation of Module Order

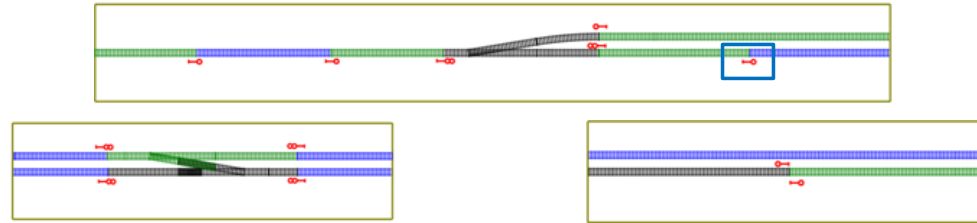



Architecture

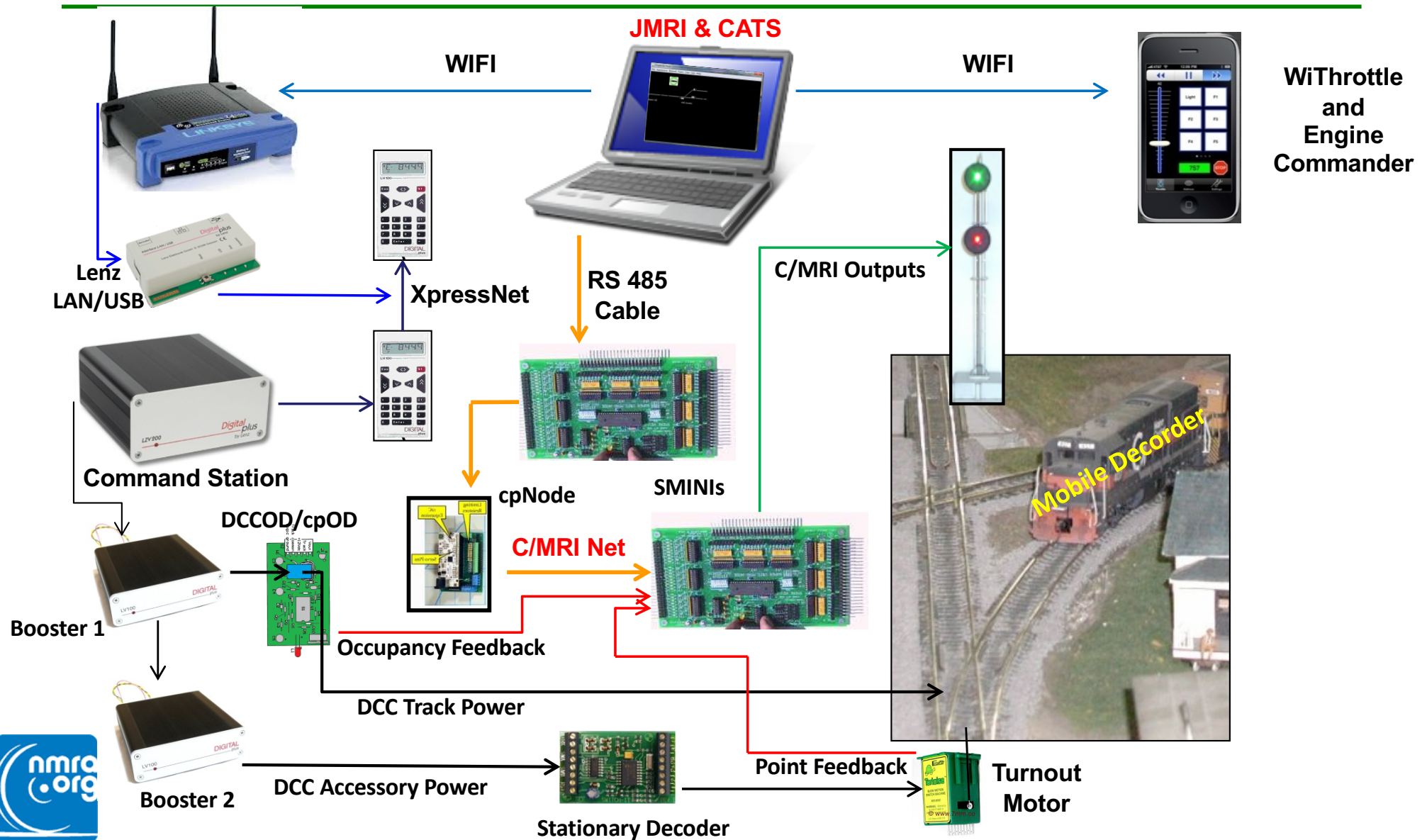



Wiring Scheme

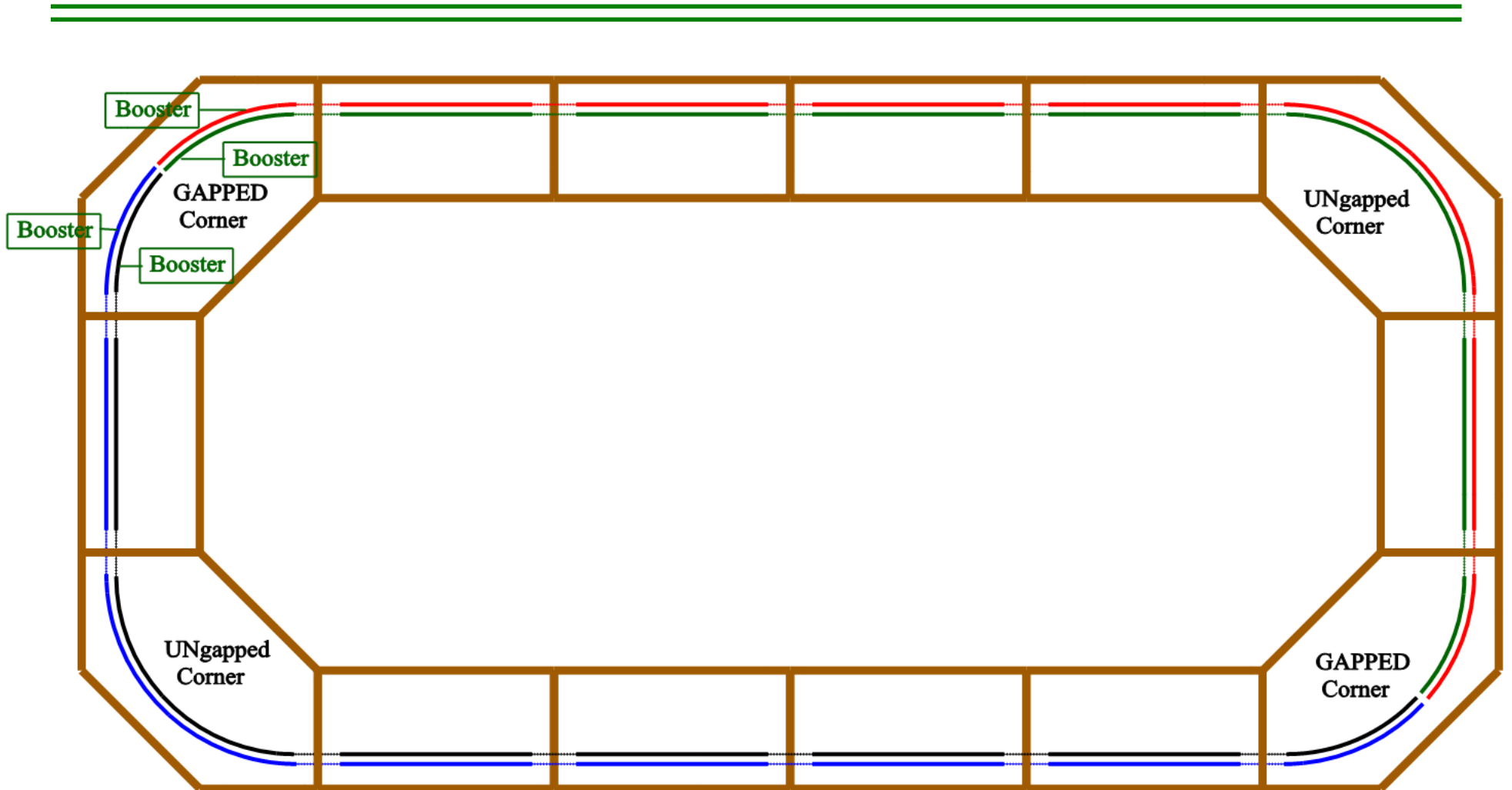



Current Module MU-ing

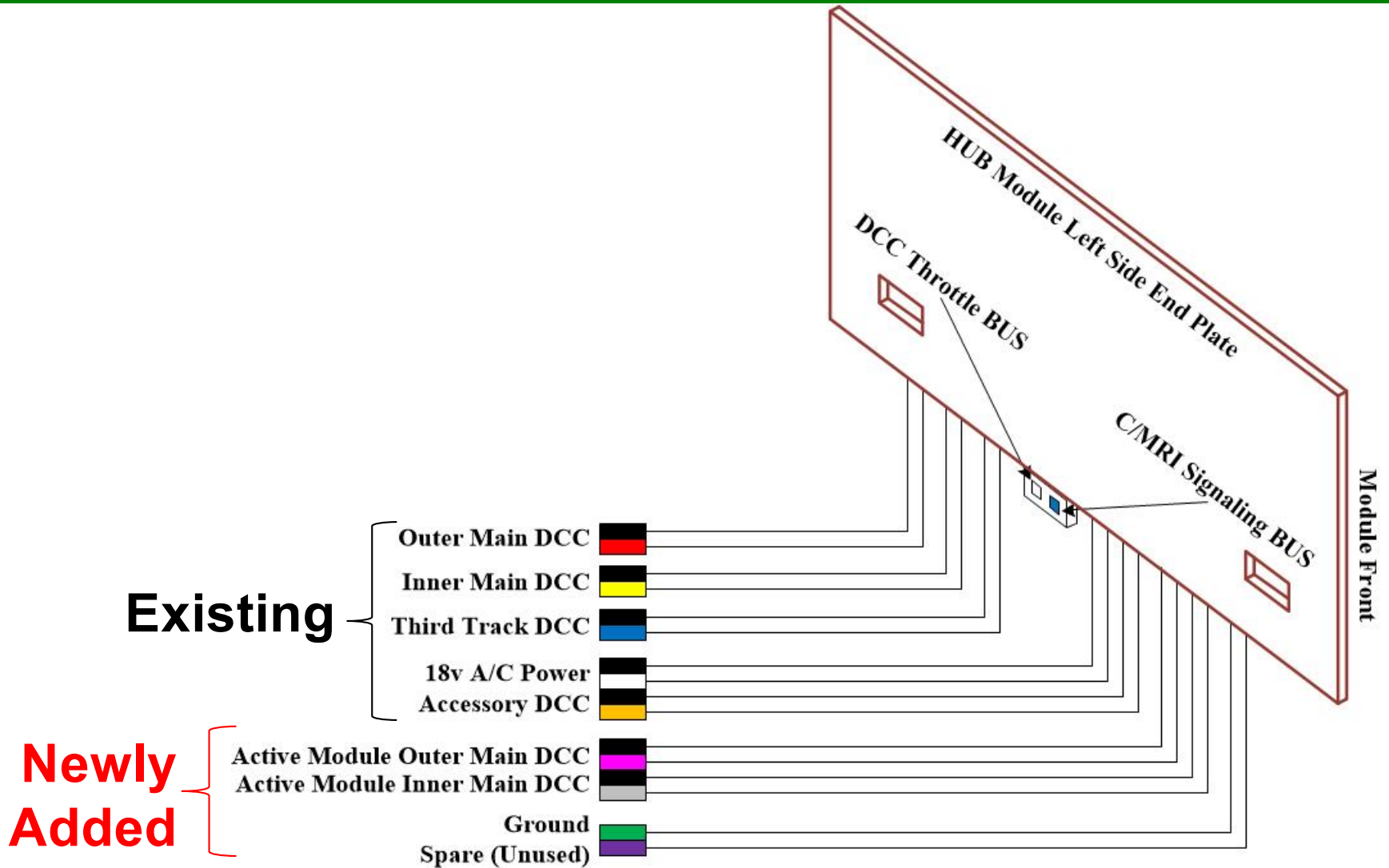



Current Module MU-ing

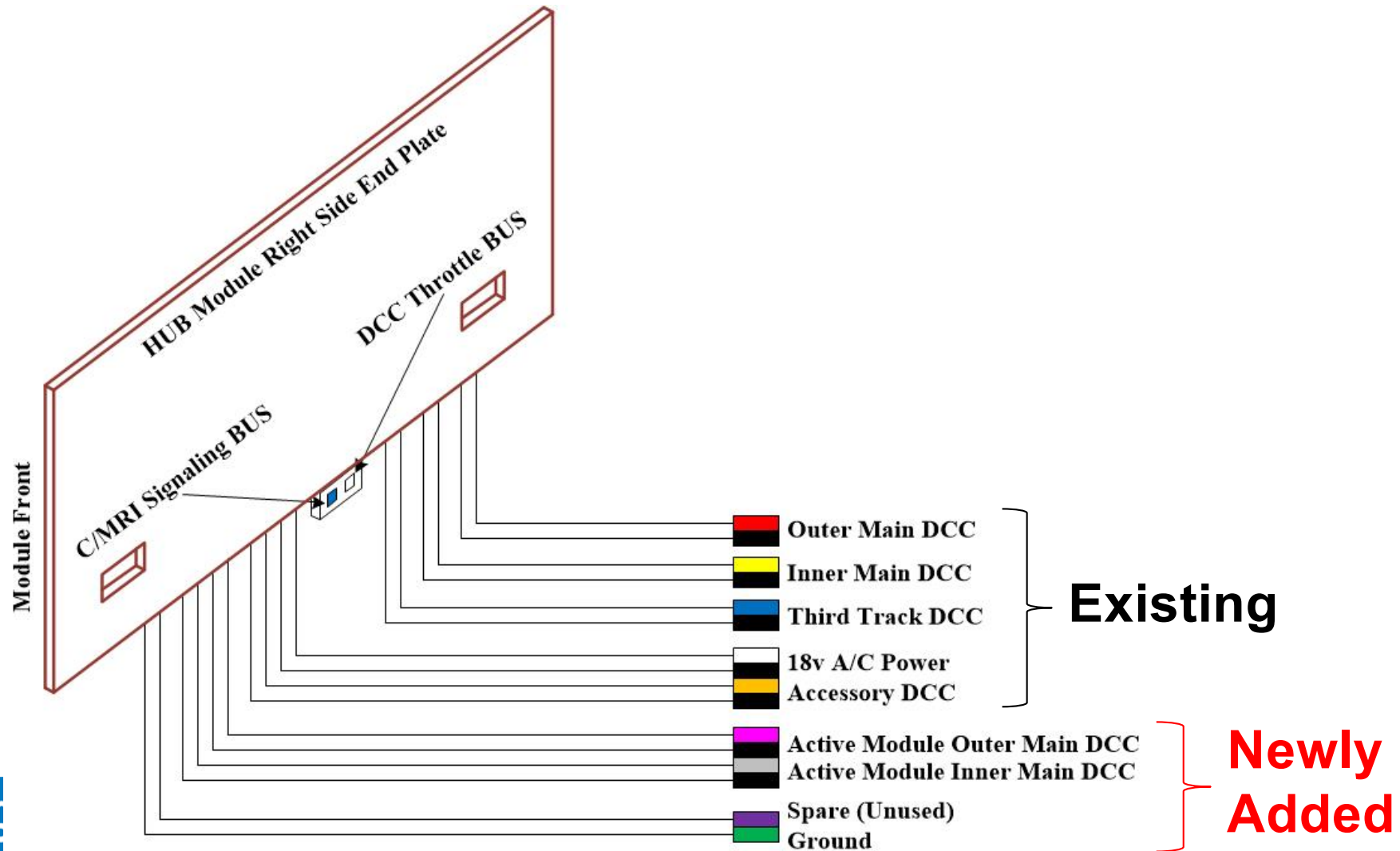



Terminal Strip Color Conventions



Wiring Harness Diagram – August 2018

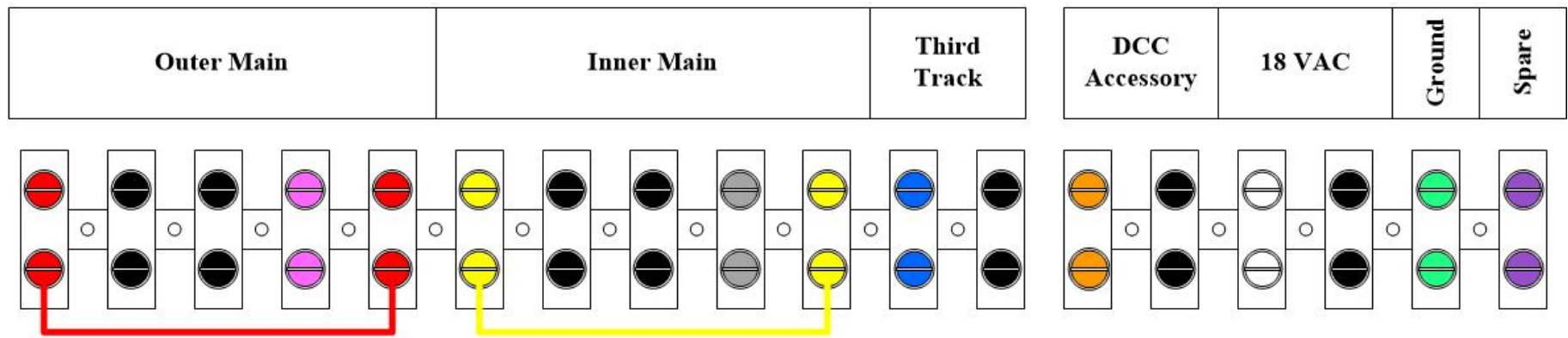

Remove Jumper Wires for Active Module



Mainline Wiring

Active Module Outside Main

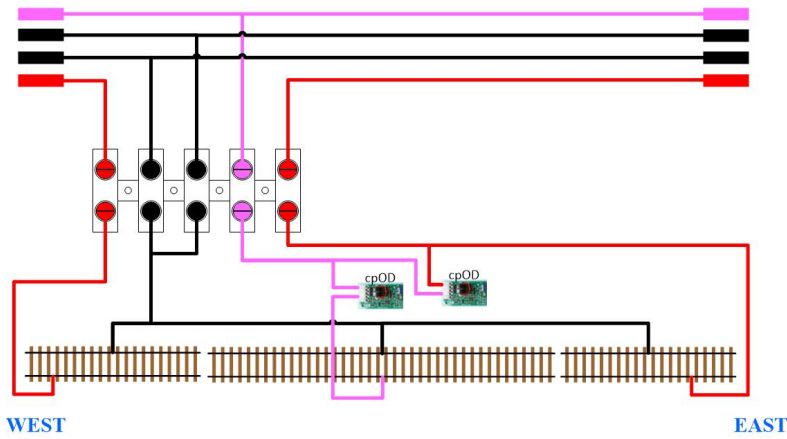

Active Module Inside Main

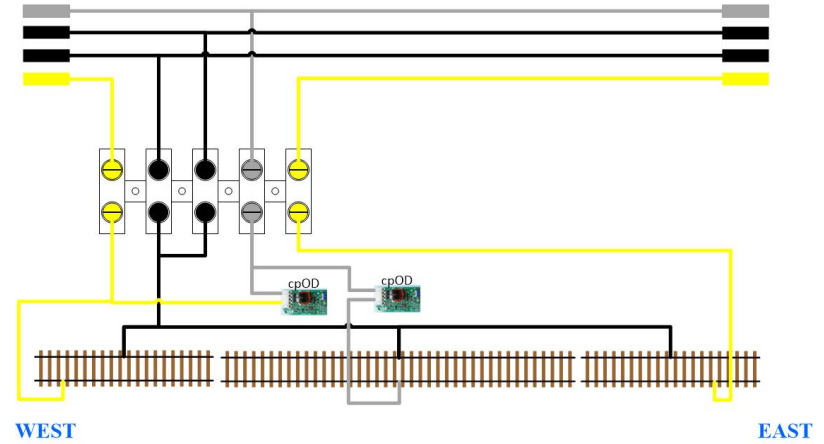

Passive Module Outside Main

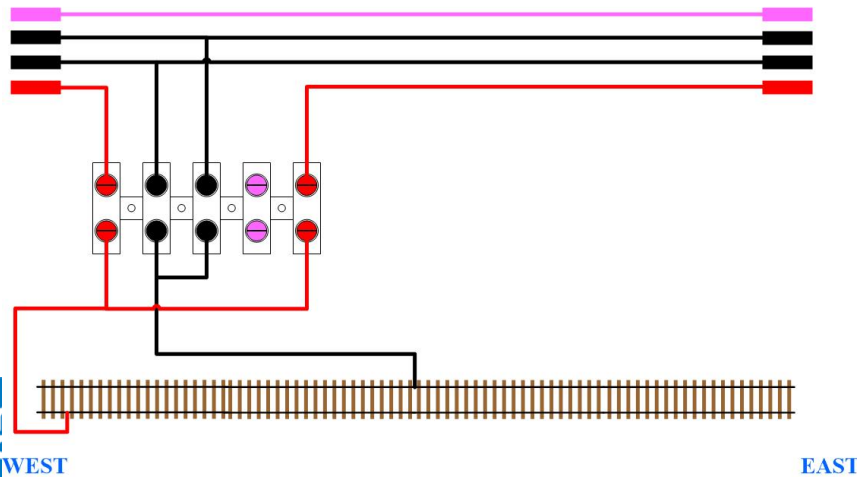

Passive Module Inside Main

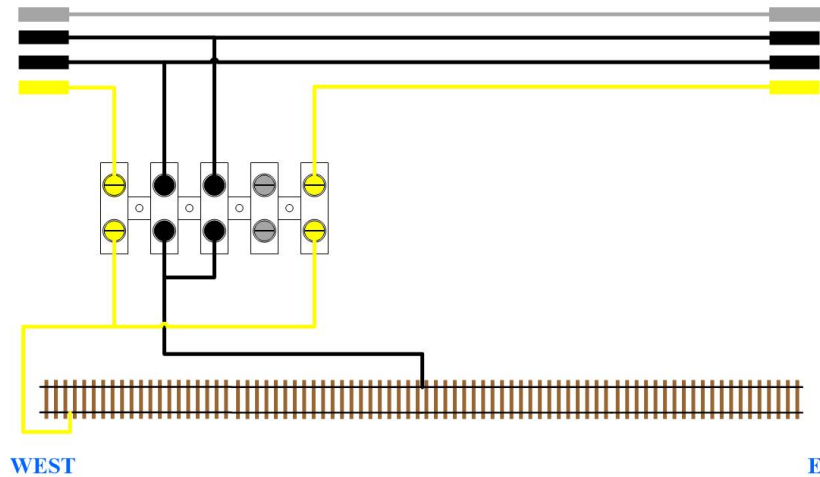



Outer Main Detail

Active Module Outside Main

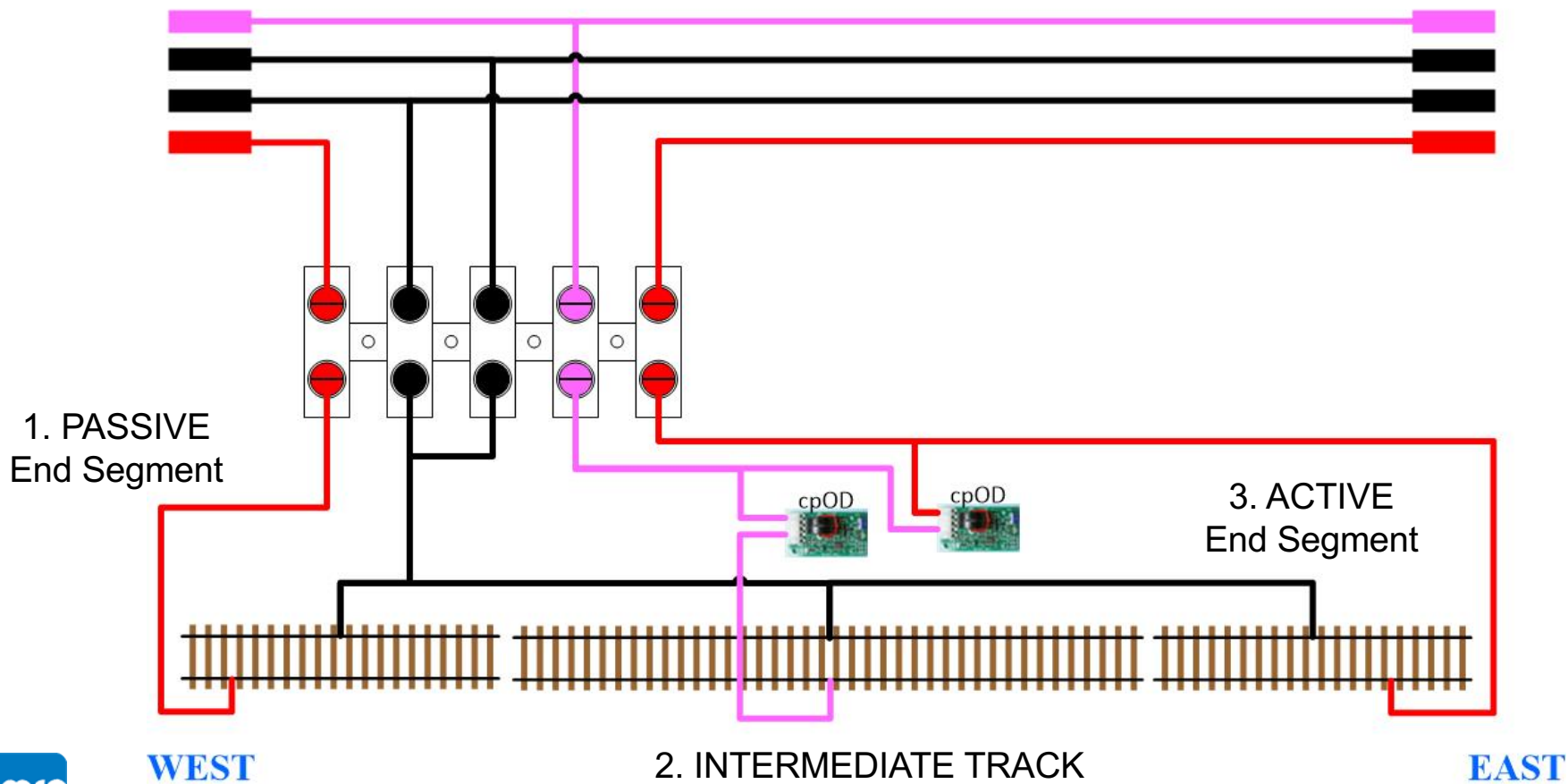



Wiring scheme

Active Module

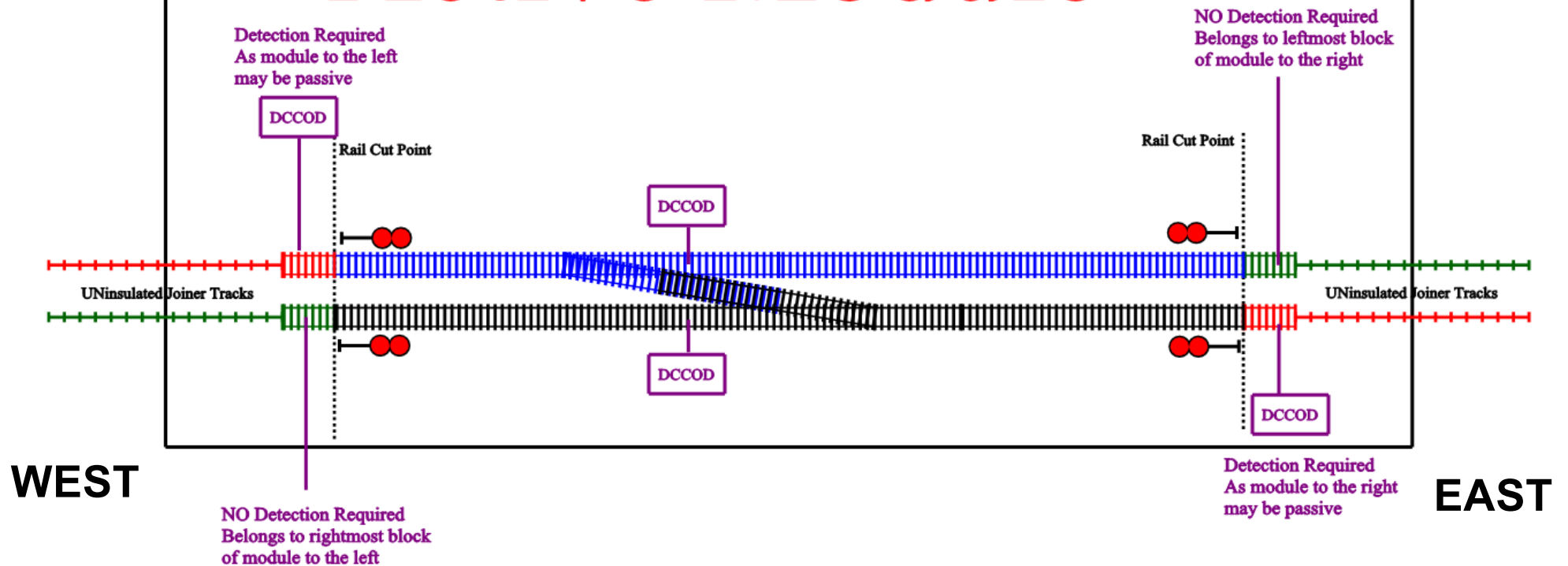



Simple Oval

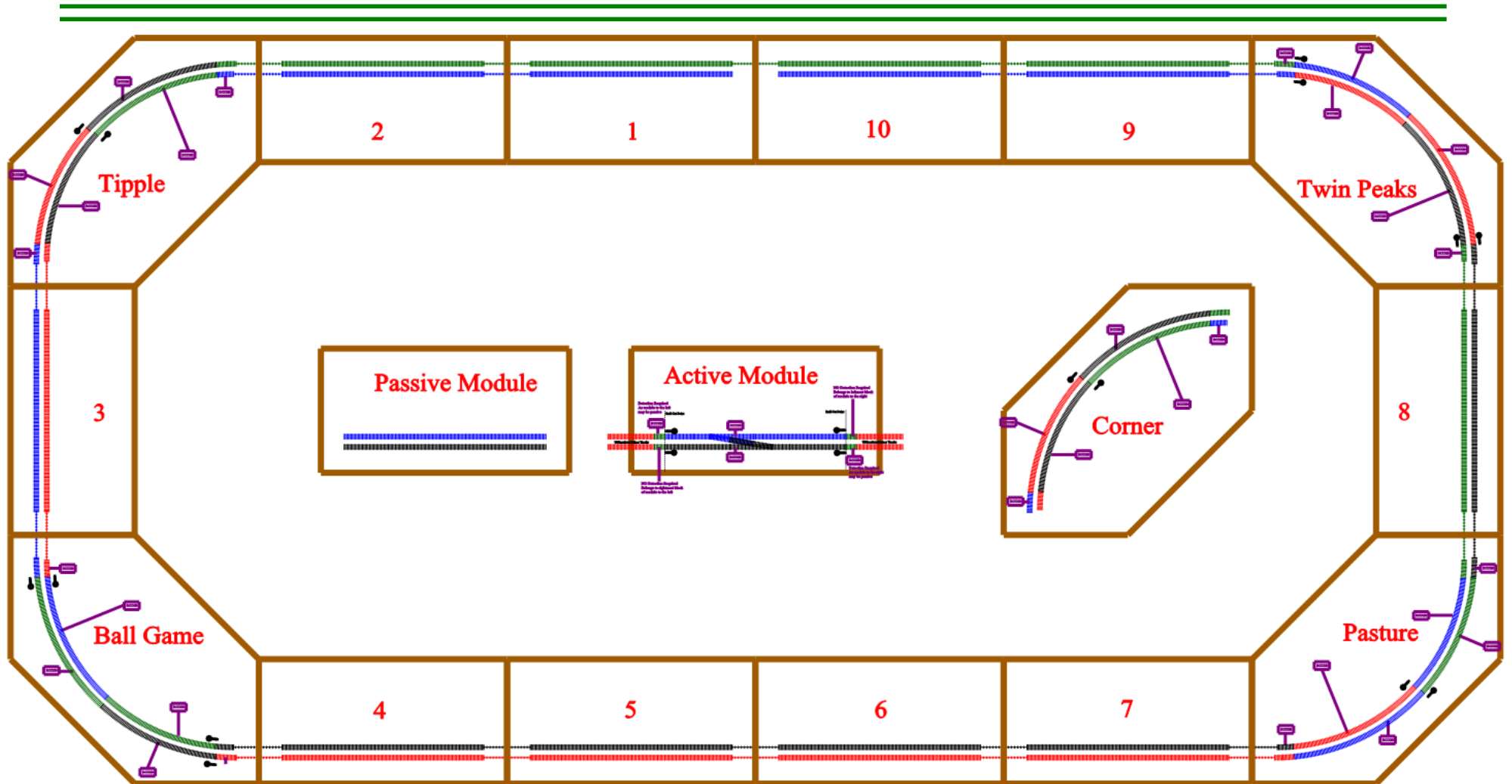



“Splicing” in Active Modules

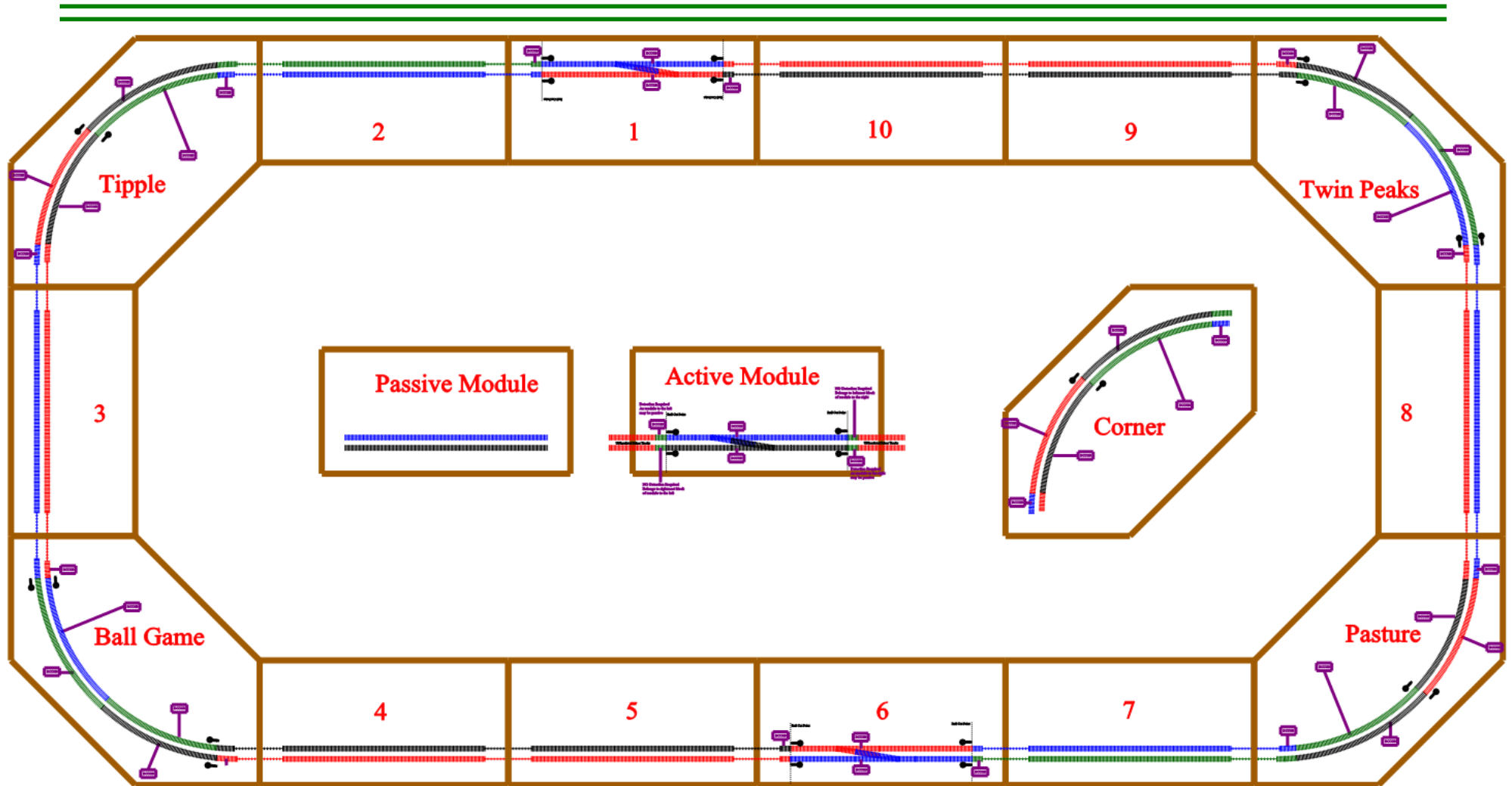



Each Module Has It's Own Designer File

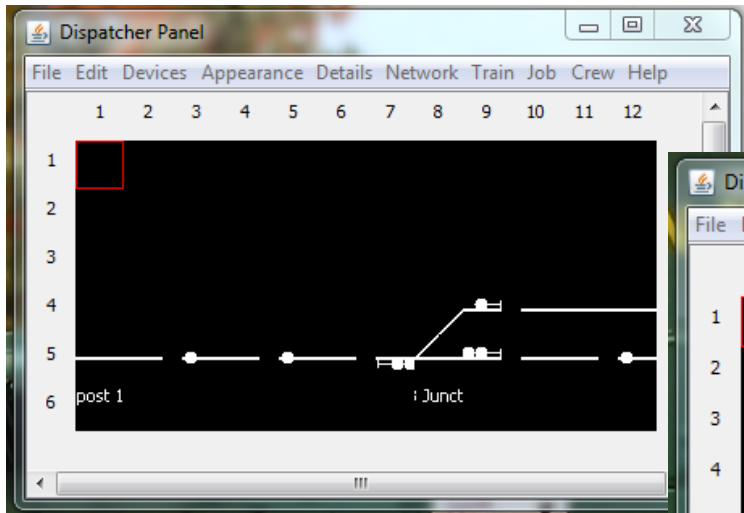

OS Module

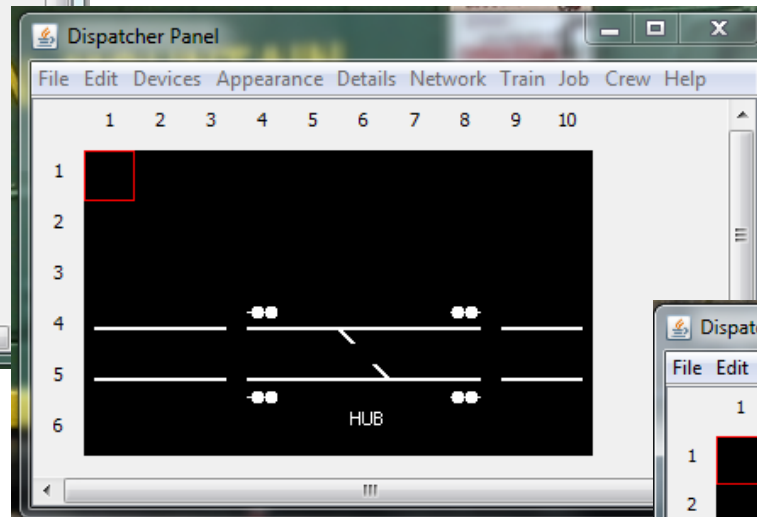

Cross-Over Module

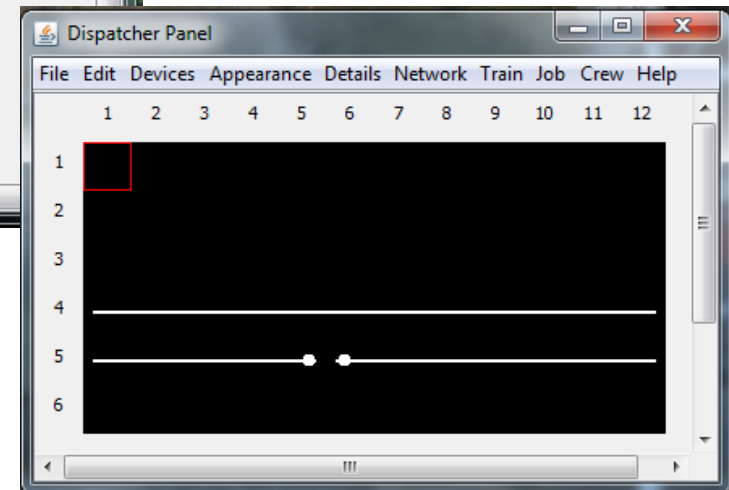

Straight Module



CATS Runtime

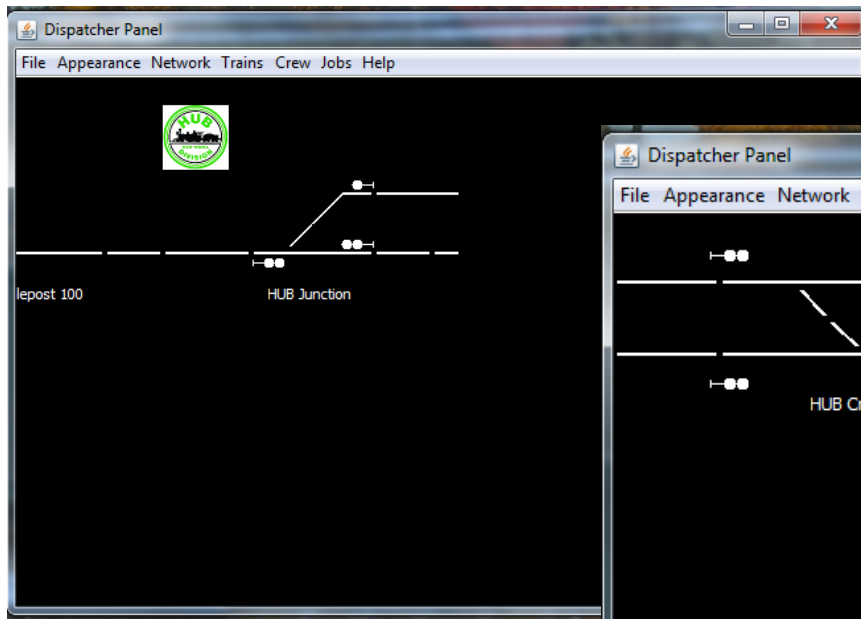

OS Module

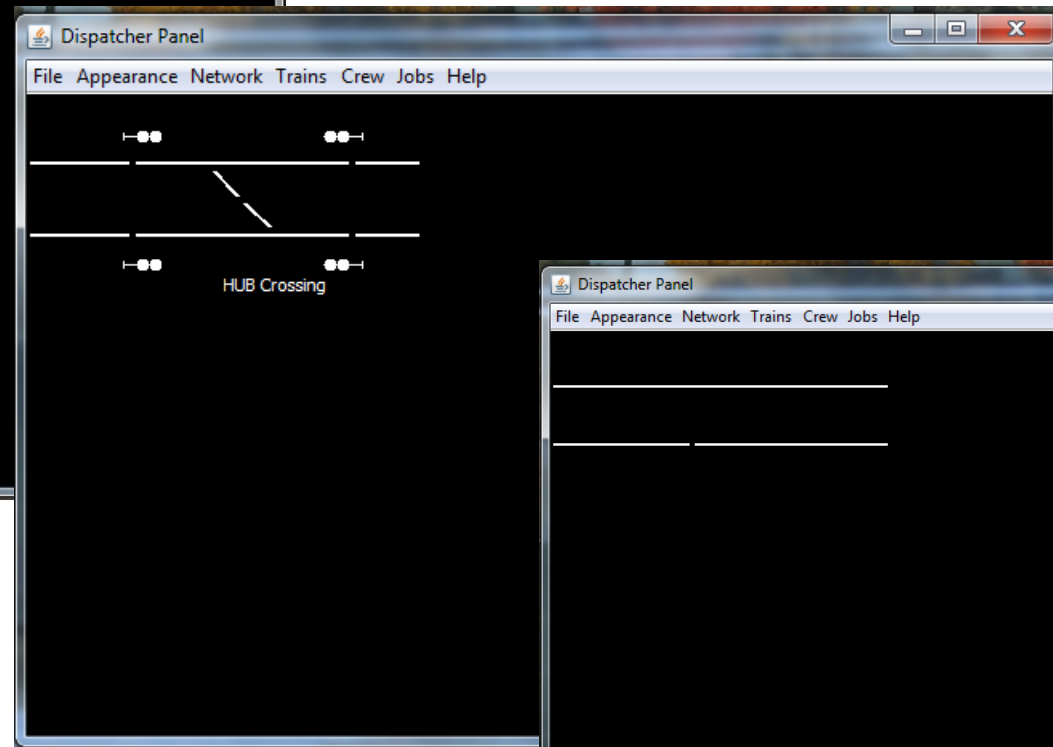

Cross-Over Module

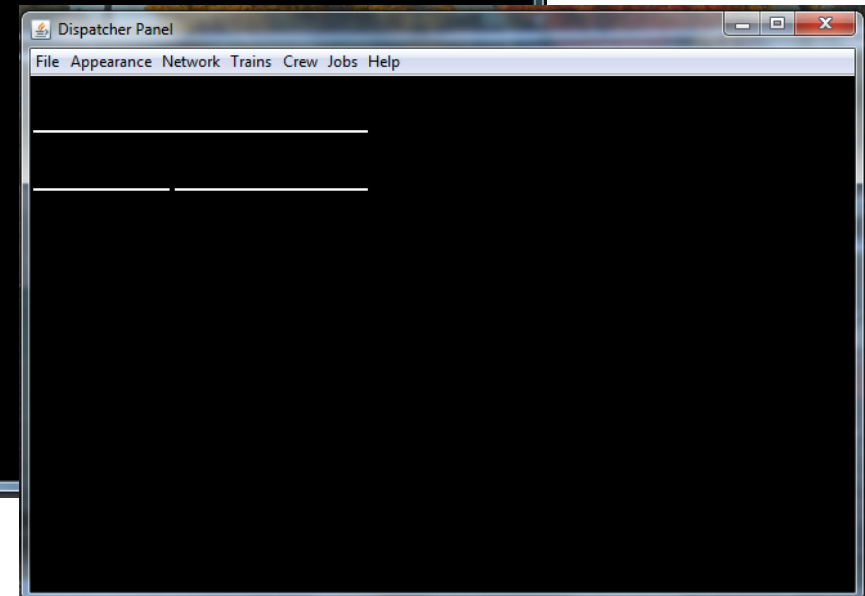

Straight Module





Runtime 3 Module Section





Hardware Evaluation Table

Manufacturer	Strengths	Reason for Elimination
C/MRI	Passed all tests	
Oaktree Systems	Reasonable price. Lots of positive testing results	Minor failure on turnout positioning. No simulator
Digitrax	Full hardware support	Signal board does not fully support all 3 color blinking aspects.
CTI Acela	Very modular, relatively low cost	Self recognizing network redefines addresses with module rearrangement. No simulator
ProTrack Grapevine	Very Modular	Possible issues with detection method. No simulator
Custom Signals	Manufactures signals as well as boards. Source for the Atlas system	Does not support JMRI. Fails a major requirement
Signals by Spreadsheet	Very clever combination of hardware and software for signaling	Does not support JMRI. Fails a major requirement
Integrated Signal Systems	Long time Manufacturer of high end signals	Does not support JMRI. Fails a major requirement



Turnout Wiring

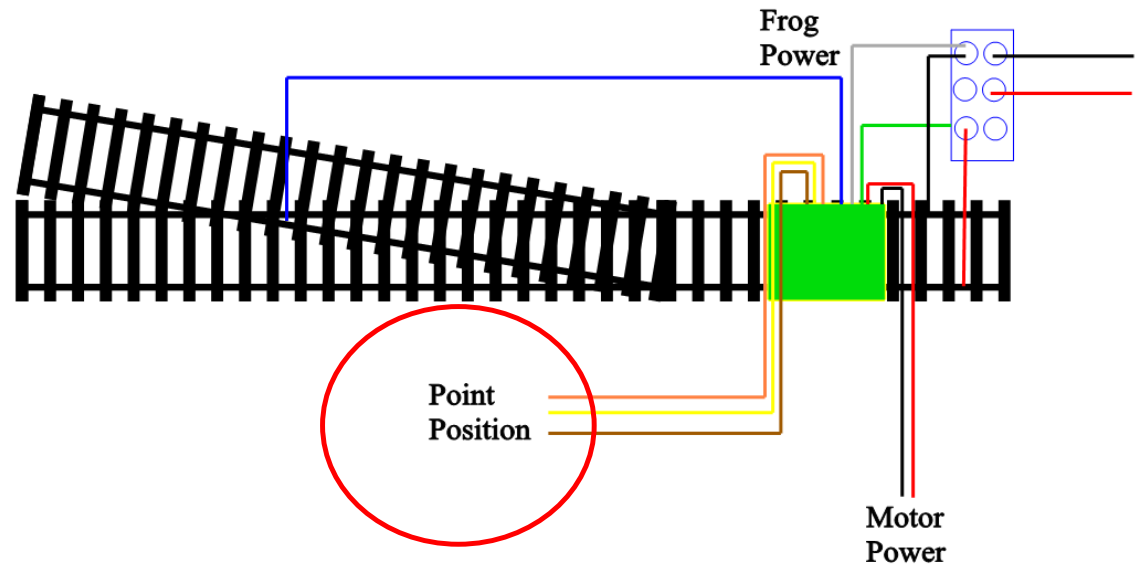
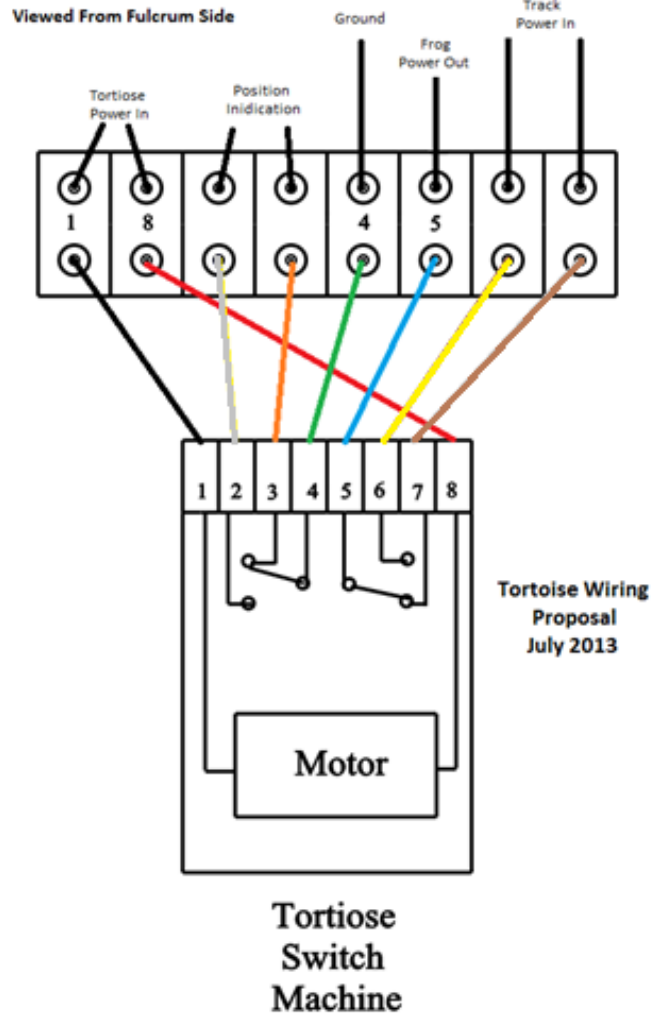



DCC Turnouts Welcome!

- We could use more crossovers on the mainlines
- **All/Most** mainline turnouts should be DCC controllable
- 3 ways to throw: throttle, pushbutton, CATS – **must agree**
- All accessory decoders are fine

• **Costs:**

	List	# TOs	Cost/TO	On-line\$	Cost/TO
NCE (SW-8)	\$ 59.95	8	\$ 7.49	\$ 49.95	\$ 6.24
Digitrax (NF)	\$ 39.99	4	\$ 10.00	\$ 31.95	\$ 7.99
NCE (SW-IT)	\$ 19.95	2	\$ 9.98	\$ 16.95	\$ 8.48
CVP	\$ 35.00	4	\$ 8.75	\$ 35.00	\$ 8.75
Team Digital	\$ 99.95	8	\$ 12.49	\$ 84.95	\$ 10.62
Digitrax	\$ 59.95	4	\$ 14.99	\$ 49.95	\$ 12.49
MRC	\$ 69.98	4	\$ 17.50	\$ 49.99	\$ 12.50
Wabbit	\$ 31.95	2	\$ 15.98	\$ 27.95	\$ 13.98
Lenz	\$ 74.87	4	\$ 18.72	\$ 59.95	\$ 14.99
RR-Cirkitst	\$ 32.25	8	\$ 4.03	\$ 27.95	\$ 3.49

† Not a DCC stationary decoder



NOTE: These prices are outdated...



Signal types

- The module group standard will be the three triangular light G-Type signal with any number of heads. Green on the right.
- However, based upon modeler preference, any physical signal type is acceptable.
- Electrically, we will only support **common anode**, lighting one LED or bulb per output. Common anode B&O or PRR signals are fine. Common cathode signals can be made to work but with considerable effort that will come only from the module owner.
- We are considering and working on approaches to removable plugs. Currently nothing formal to report





Signal Connections Work in progress

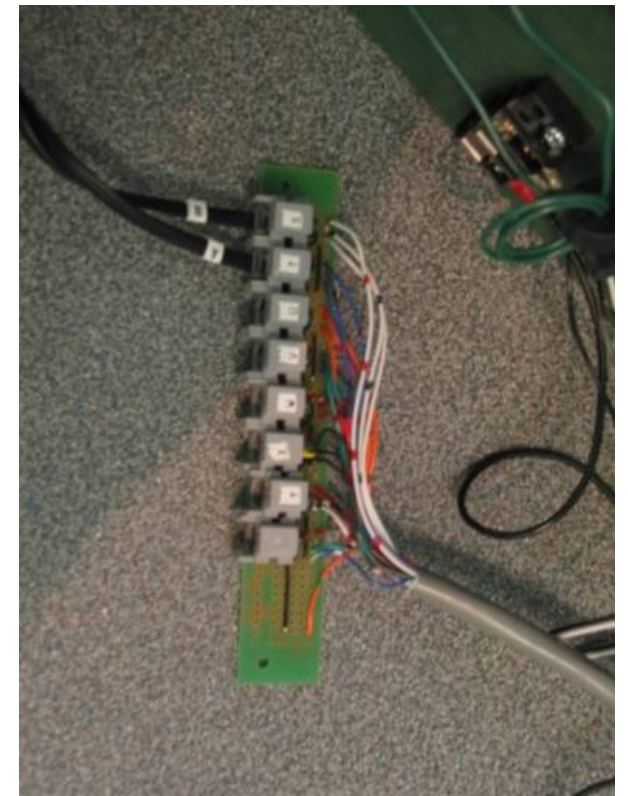
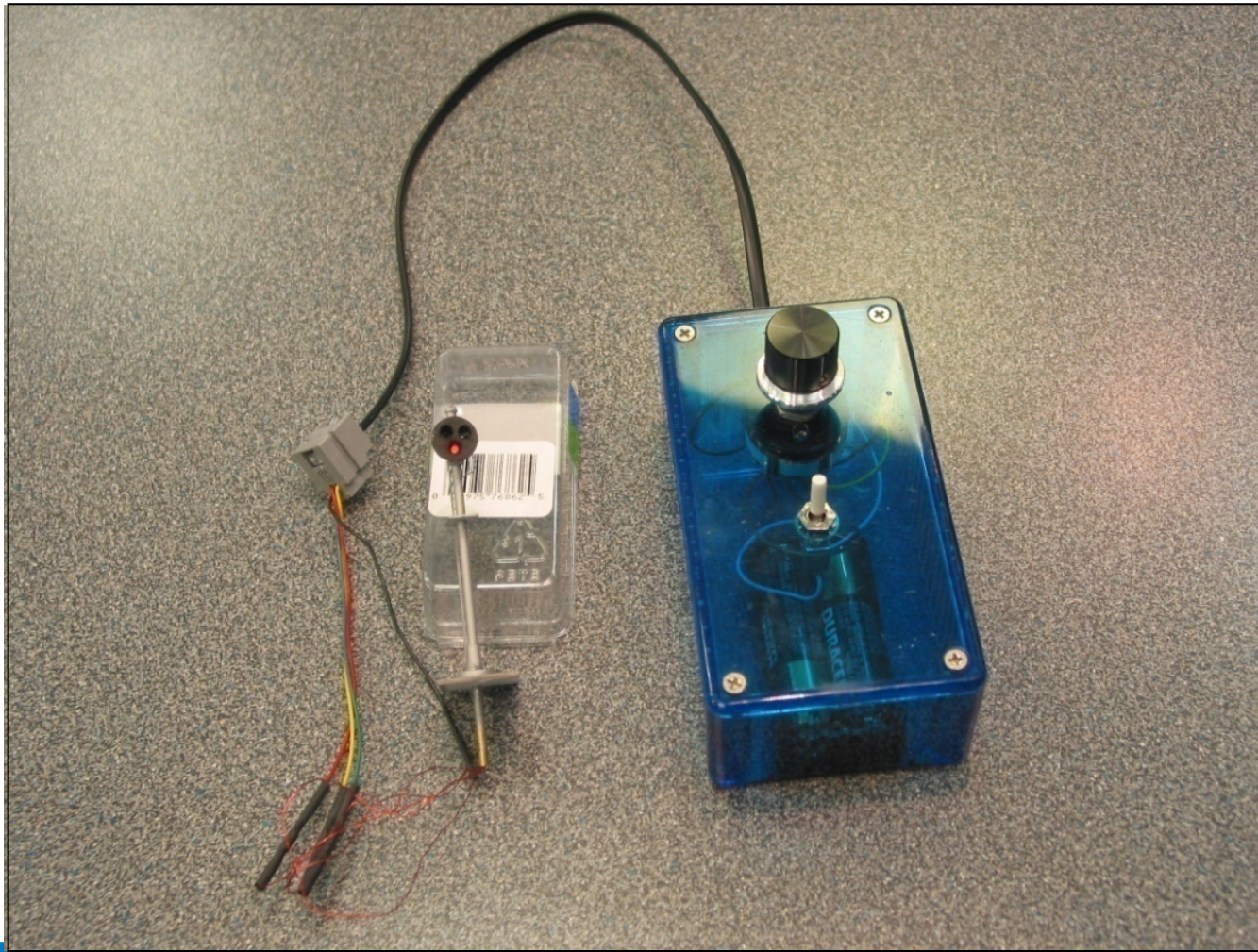



CHUBB to HUB

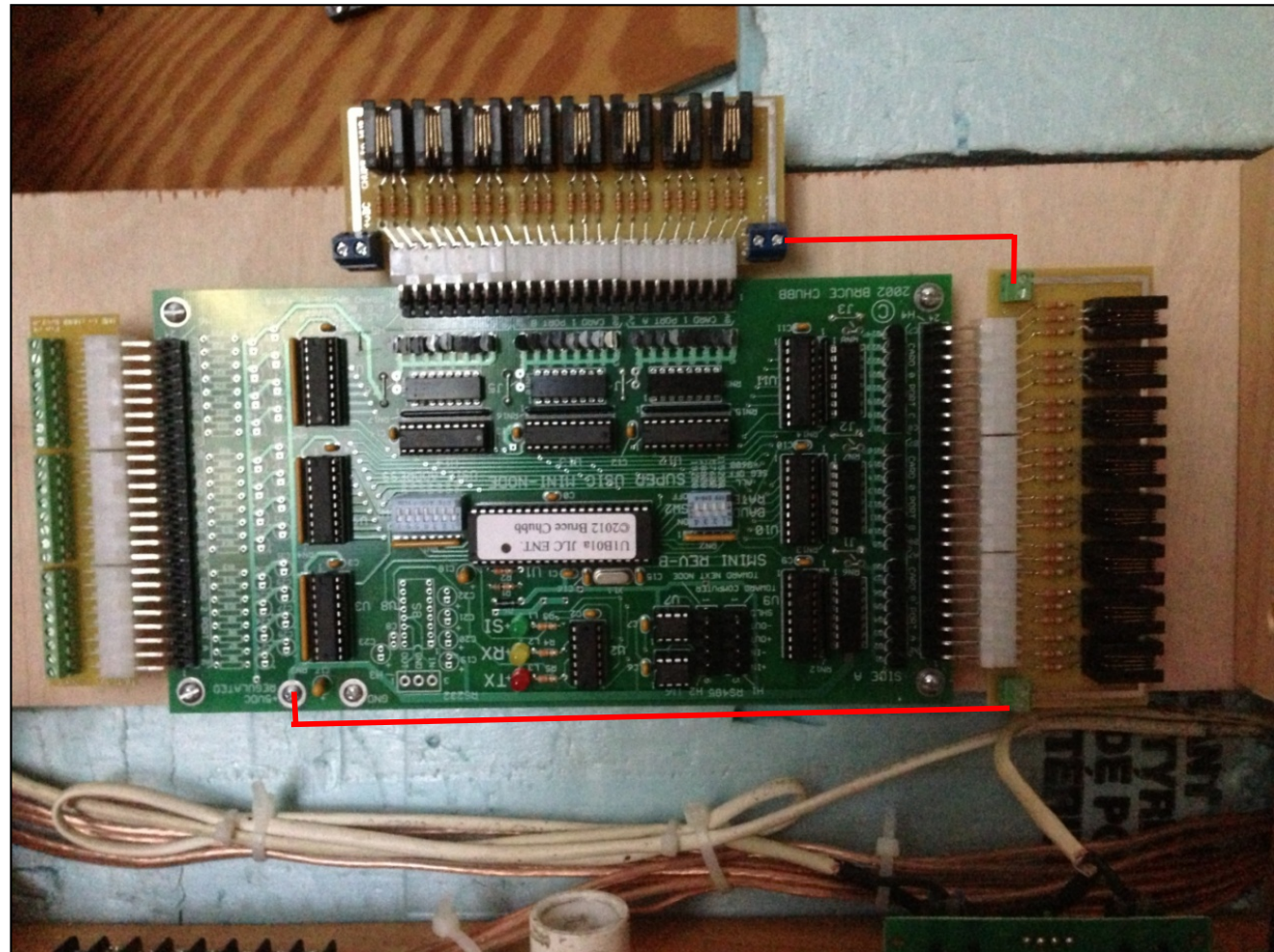
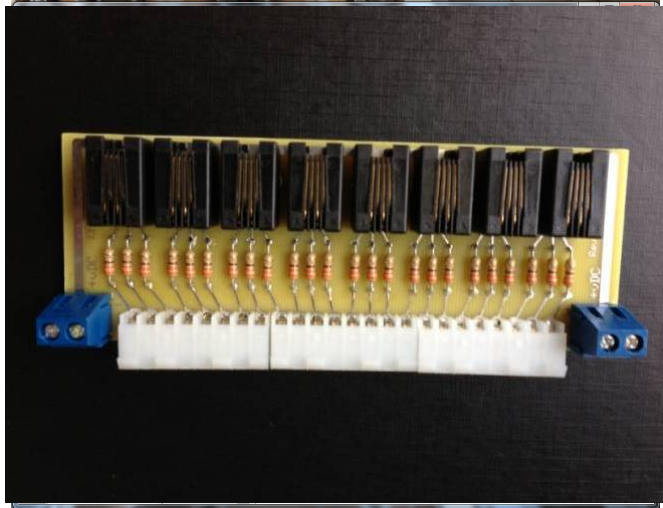



Searchlights



2 lead bipolar LED

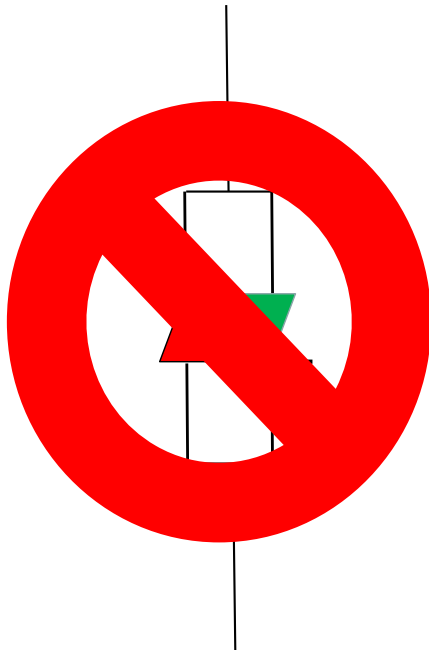

3 lead Common Cathode LED

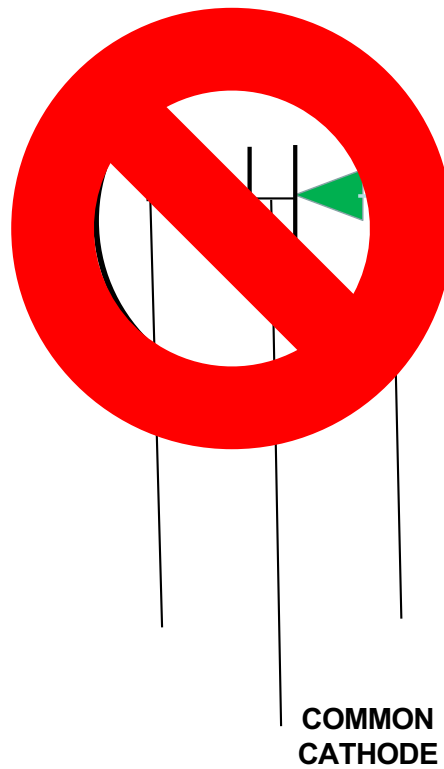

4 lead Common Anode LED





Commercial Signals

(somewhat outdated)



NJ International

#1053 \$32.99	#1054 \$34.99	#1056 \$36.99
------------------	------------------	------------------

Tomar

#H-855 \$26.30	#H-865 \$49.70
-------------------	-------------------

Oregon Rail Supply (KITS)

#116 \$11.95	#538 \$19.95
-----------------	-----------------

Custom Signal Systems

G-Double
\$30.00

South Bend

SB-G
\$20.00

Custom Signal (Atlas) Common Cathode

<small>N & HO Single Target Signals</small> #235 \$34.95	<small>N & HO Double Target Signals</small> #238 \$44.95	<small>N & HO Bi-Directional Target Signals</small> #239 \$44.95
---	---	---





Detection – Chubb DCCOD



- How is it powered? **12v unregulated DC**
- Does it use transformer coupling? **YES**
- Is the sensitivity adjustable? **YES**
- Built-in de-bounce (3.5 sec off, 250 ms on)
- How much resistance in cars? **4700 Ohms**
- Fraction of cars with resistors? **100% - 1 Axle**
- Low cost source of resisted wheelsets
- C/MRI DCCODs as kits (around \$10)

New Kids on the Block

cpNode

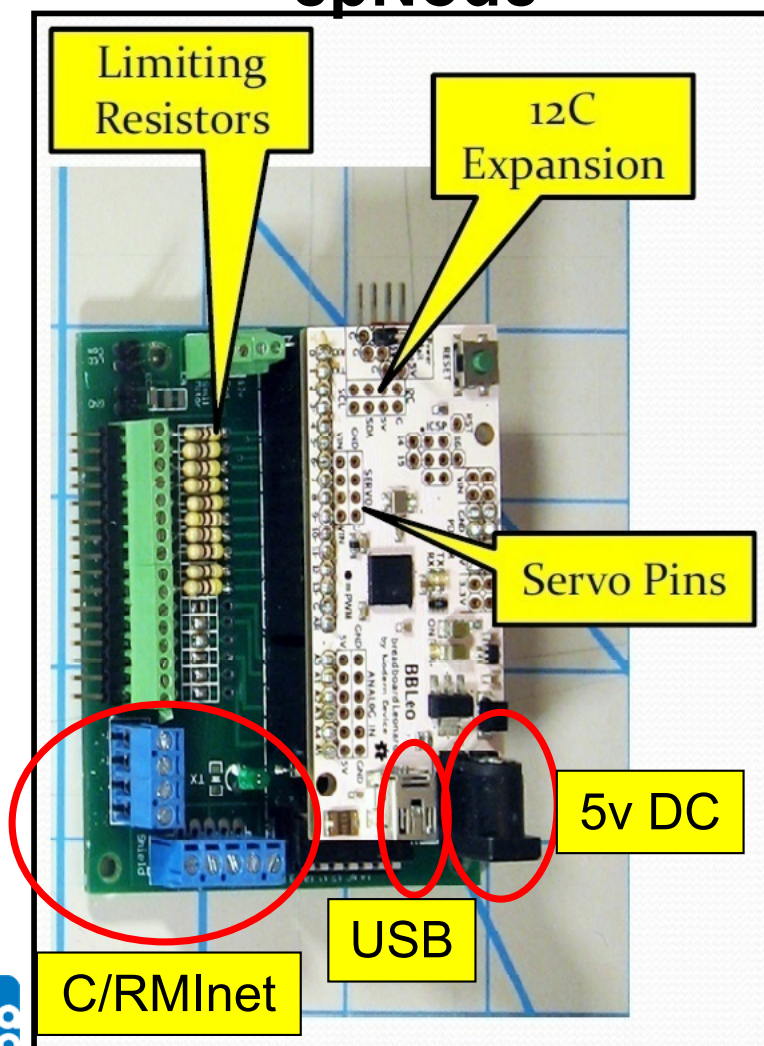

- Arduino based
 - 16 Configurable ports
 - Configurable node address
 - Configurable baud rate
 - Behaves like an SMINI
 - Small: 3 x 2 ½ inches
 - Low cost
 - Built-in Turnout control
 - Expandable
-
- cpOD equivalent to DCCOD but smaller and inexpensive



Straightforward Modules



Requirements: 3 Sensors
6 Outputs

cpNode: 10 outputs, 6 inputs
SMINI: 48 outputs, 24 inputs

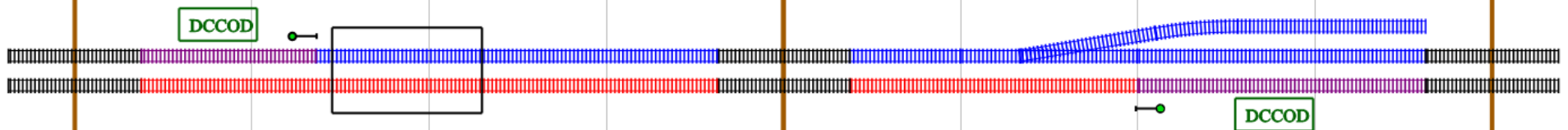



If I Only Had a Few More Pins



cpNode with an IOX16
•6 Sensors (inputs)
•26 Turnouts (outputs)

Requirements:
4 two headed G-type
Signals: 24 LEDS
6 DDCODs

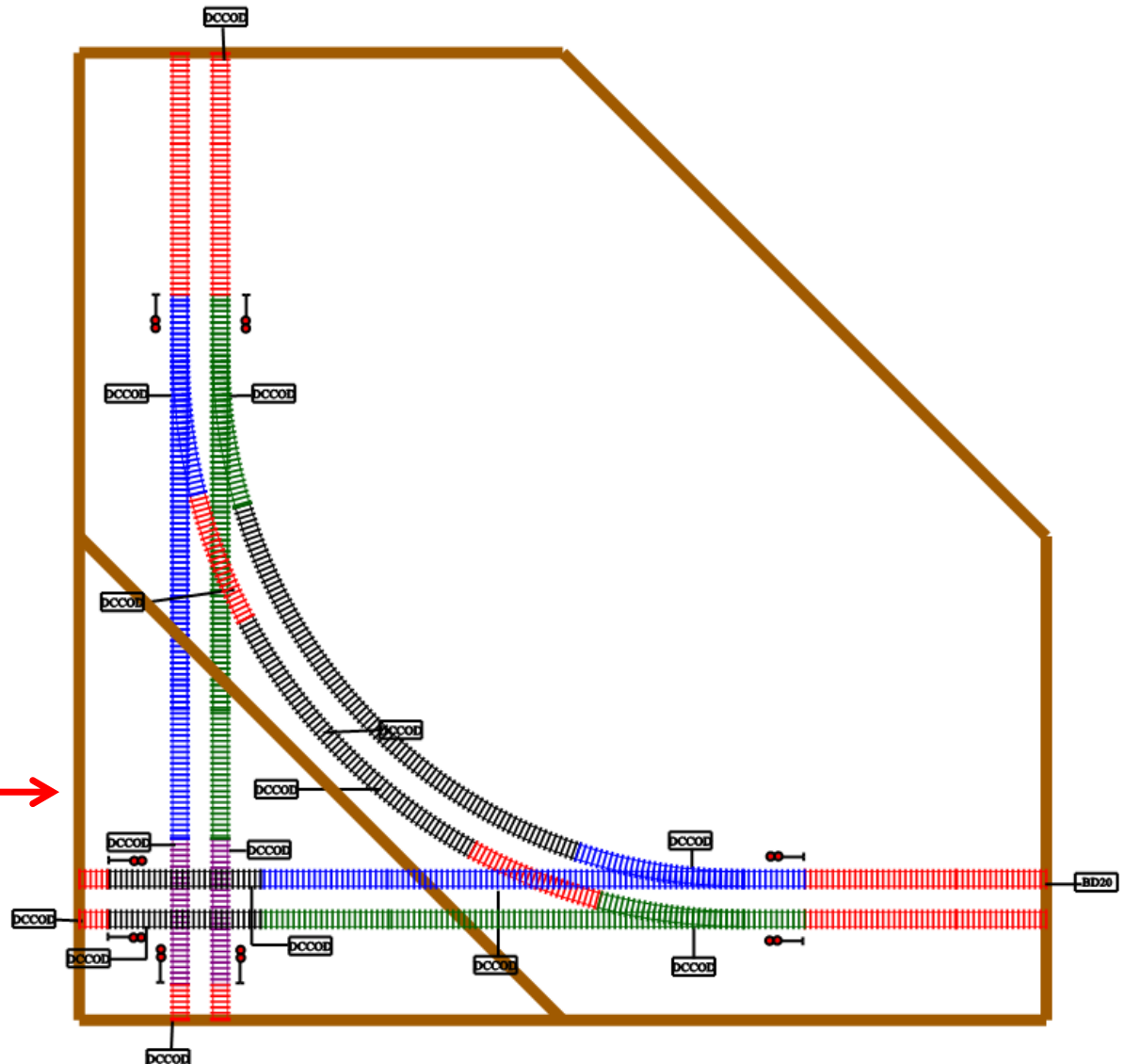



Signal Parsimony is Good



11 signals to start

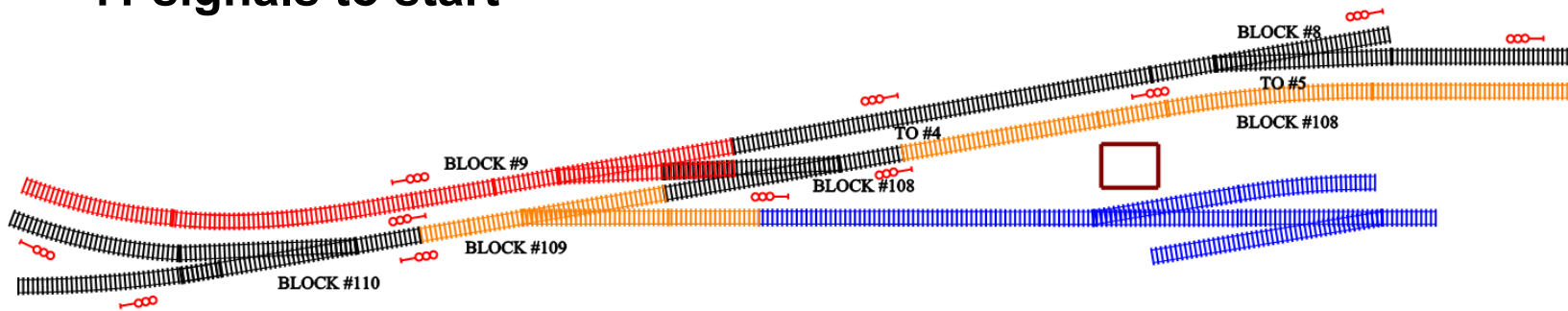

7 signals after removal and repositioning
37% reduction

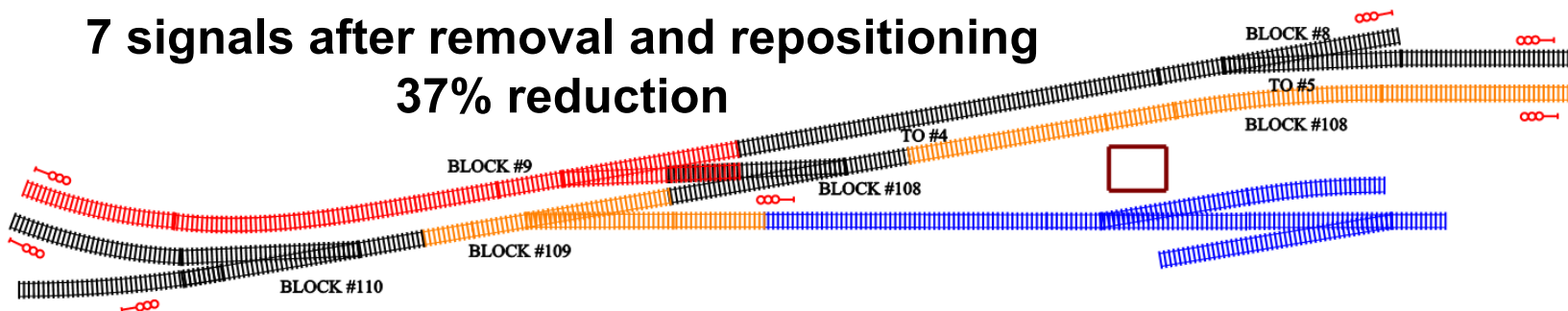

- Fewer Signals = lower cost
- Don't signal dark territory



Power Requirements

- DCCODs & cpODs (12v DC unregulated)
- SMINIs & cpNodes (5v DC regulated)
- Tortoises (12v DC unregulated)
- HUB NMRA Layout AC Requirements

	Draw	Number	Total
SMINI	0.350	12	4.2
LED	0.020	80	1.6
DCCOD	0.020	60	1.2
			7.0



Corner Modules

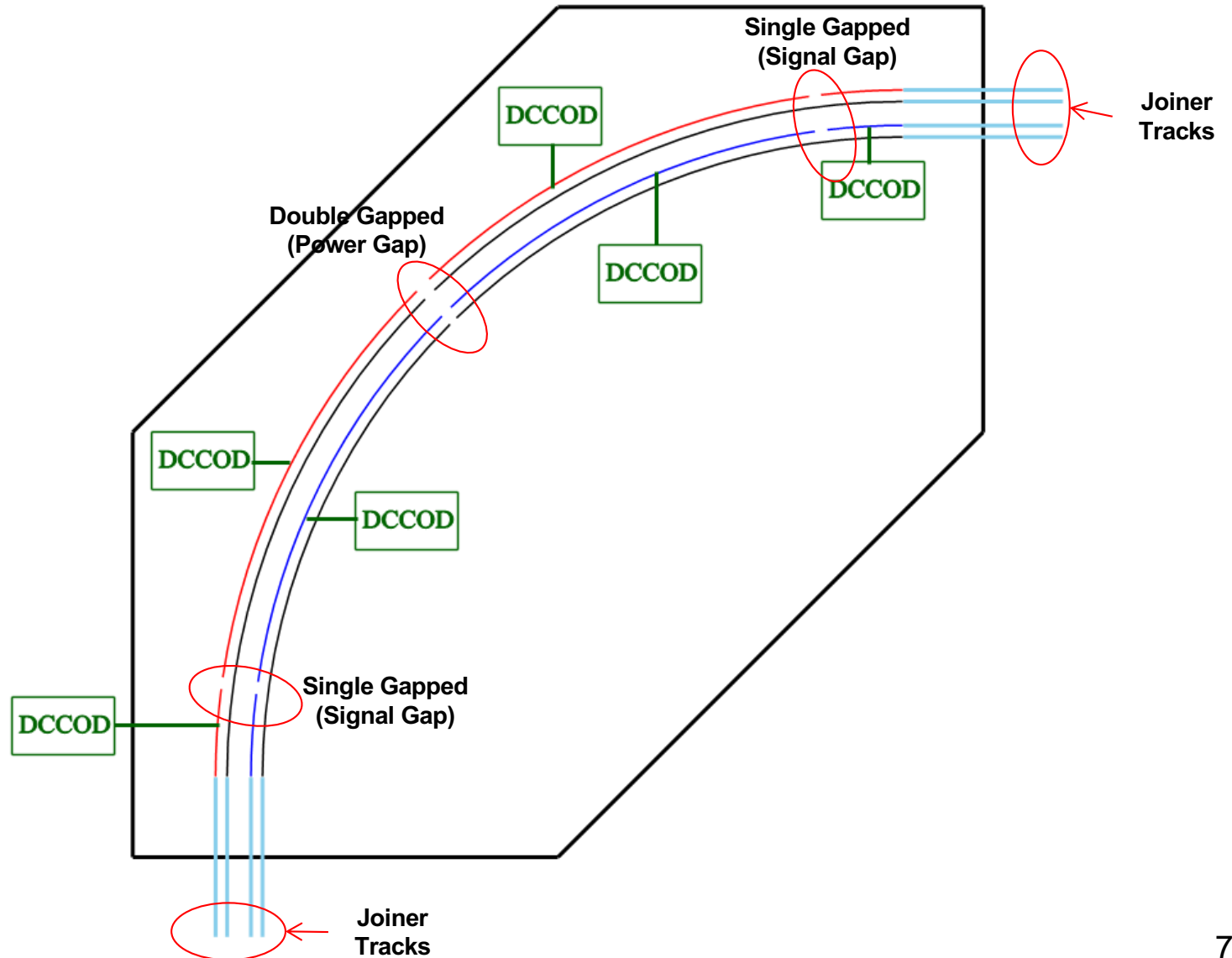



Pasture (documentation)

Chubb Board Address = 2

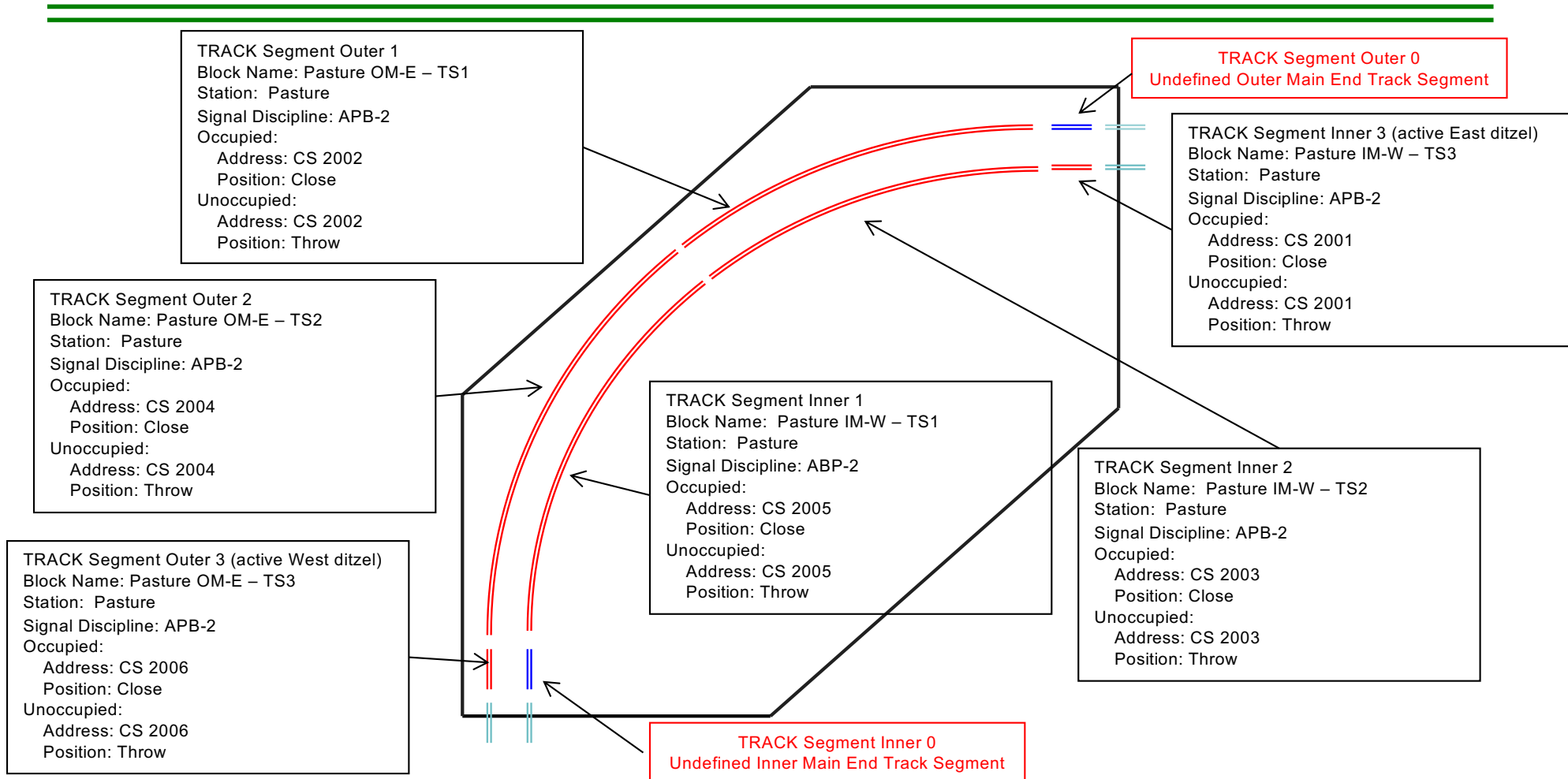



Manual Documentation

HUB CATS File Development Documentation

Upton Yard Signal Program file East Module Signal Block Definitions

Block Definition			Actual Signal Location on Module	Define Signal		Details/Signal Head Definitions				
Block Name	Signal Discipline	Address "CS"		Panel Placement		Actual Head	Details	Aspect	Address "CT"	
			In Tile	Facing						
Upton Yard OME TS2	CTC	7004	Outer Main	Upleft	Left	Top	Head0	Red	7001	Software Flashing
								Yellow	7002	
								Green	7003	
						Middle	Head1	Red	7004	
								Yellow	7005	
								Green	7006	
						Bottom	Head2	Red	7007	
								Yellow	7008	
								Green	7009	
Upton Yard IMW TS1	CTC	7001	Inner Main	Upleft	Left	Top	Head0	Red	7011	Software Flashing
								Yellow	7012	
								Green	7013	
						Middle	Head1	Red	7014	
								Yellow	7015	
								Green	7016	
						Bottom	Head2	Red	7017	
								Yellow	7018	
								Green	7019	
Upton Yard LE TS1	CTC	7011	Local	Upleft	Left	Top	Head0	Red	7021	Software Flashing
								Yellow	7022	
								Green	7023	
						Middle	Head1	Red	7024	
								Yellow	7025	
								Green	7026	
Upton Yard EYL TS3a	CTC	7010	Yard Exit	Rightlow	Bottom	Top	Head0	Red	7027	Software Flashing
								Yellow	7028	
								Green	7029	
						Middle	Head1	Red	7030	
								Yellow	7031	
								Green	7032	
						Bottom	Head2	Red	7033	
								Yellow	7034	
								Green	7035	





CatNip



Newton Junction - Microsoft Excel non-commercial use

Home Insert Page Layout Formulas Data Review View Acrobat

Clipboard Font Alignment Number Styles Cells Editing

A2 Location

	A	B	C	D	E	F	G	H	I	J	K	L
	Location	Name	Head Name	Software Flashing	Color	Prefix	Address	Action	Off Command			
1												
2												
3	Column 5 Row 1	RSJ SL3	Undefined									
4												
5												
6	Column 5 Row 7	RSJ SL2	Stony Brk North Upper		green	CT	13026	throw	TRUE			
7					yellow	CT	13027	throw	TRUE			
8					red	CT	13025	throw	TRUE			
9												
10			Stony Brk N Lower	TRUE	red	CT	13028	throw	TRUE			
11					flashing green	CT	13029	throw	TRUE			
12					yellow	CT	13030	throw	TRUE			
13					green	CT	13029	throw	TRUE			
14					flashing yellow	CT	13030	throw	TRUE			
15												
16												
17	Column 3 Row 8	RSJ SL3	NewtonJct IM West Upper		green	CT	13032	throw	TRUE			
18					yellow	CT	13033	throw	TRUE			
19					red	CT	13031	throw	TRUE			
20												
21			Newton Jct IM West Middle	TRUE	red	CT	13034	throw	TRUE			
22					flashing green	CT	13035	throw	TRUE			

Ready Count: 9 100%





New Challenges



- Detection sensitivity
- Compatibility with other modular groups
- Approaches to removable signals
- Track complexity
 - Wiring track power
 - The bridge module has become the “draw bridge” module
 - Linearize the signal bus

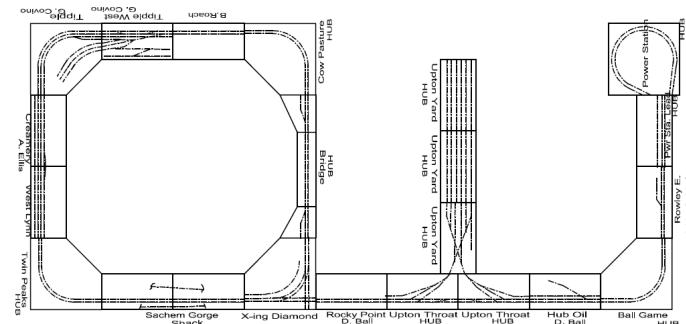
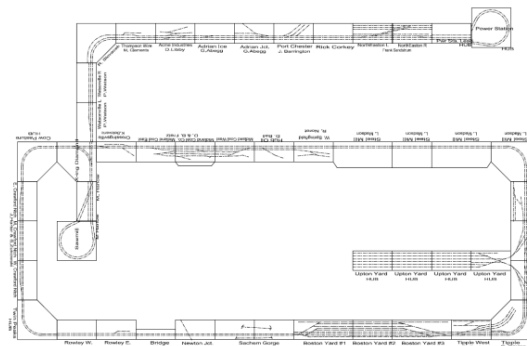
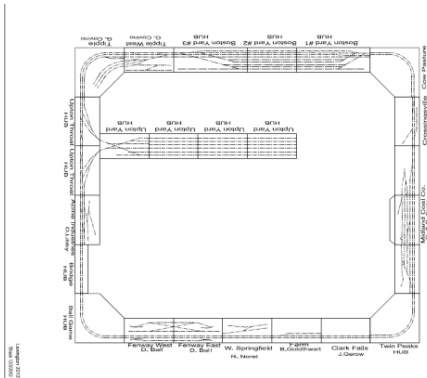



Clearance Form "A"

- This is the form that makes a train a train
- We use it to fill in the needed info for train tracking

CLEARANCE FORM "A"		Date	APRIL 25, 2014
STATION			
LAFON YARD			
CONDUCTOR AND ENGINEER			
DICK JOHANNES			
ORDERS (If no orders, indorse "NONE")			
OK AT (Time)		CHIEF DISPATCHER	
11:00 AM		Shock Hamilton	
DO NOT LEAVE BEFORE (Fill in when necessary to comply with rule 221)			
TRAIN NAME		BLOCK (Fill in only when operating under Manual Block System)	
EDPO			
LEAD LOCOMOTIVE		# CARS (At Origination)	
#510		17	
Conductor and engineer must have a copy and see that their train is correctly designated in the above form, also that the numbers of all train orders received correspond with numbers inserted above.			
DA FORM 4091-R, 1 May 93		REPLACES DA FORM 55-200 1 Jan 90 WHICH IS OBSOLETE	





Summary of Original Signaling Committee Work



- Signaling a modular layouts can be done without constraining either the sequence of modules or limiting the function of the signaling system
- Can run with or without a dispatcher
- Pre-setup: Create linear list of modules “importing” the layout plan for that particular setup into CATS
- Setup = 1) Link the physical modules 2) Load the CATS equivalent 3) Run
- HUB modular railroad uses:
 1. Lenz DCC with a LAN-USB connection
 2. C/MRI SMINI boards + (cpNodes & SMicros)
 3. C/MRI DCCOD occupancy detectors
 4. JMRI & CATS software



HUB Division Website

<http://www.hubdiv.org/signalComm.htm>



The screenshot shows a web browser window with the URL <http://www.hubdiv.org/signalComm.htm>. The page features a navigation menu with links for Home, About the HUB Division, Activities & Articles, Our Shows, Our Store, Photos, Other Organizations, and Links. The main heading reads "The NMRA HUB Division Modular Railroad Signal Committee". Below this, there are sections for "Signaling Presentations" (including HUB Modular Railroad Signaling Documentation, Address & Number Assignments, Signal Committee Meeting Notes & BOD Reports, and Vendor Links) and "Committee Origins & Goals". A sidebar on the left contains buttons for Home, Calendar, Headlight, Member Articles, and Module Group, along with a "Join" button and "HUB Member Services" (Mailing List, Library). Social media links for Facebook, Twitter, and YouTube are also present.

Signaling Presentations
HUB Modular Railroad Signaling Documentation
Address & Number Assignments
Signal Committee Meeting Notes & BOD Reports
Vendor Links

Committee Origins & Goals
Discussions on signaling the HUB Modular Railroad began in the spring of 2010. At the 75th NMRA convention that summer, the project started to take root when Dick Johannes, Jeff Gerow and Stan Ames attended a Signal Seminar at the convention. In addition, Dick attended any and every session on signals on model railroads he could find, with the other two members attending many of them alongside him. They returned to Boston energized with the concept that signals could be done on a modular railroad. The problem was how, since signal systems are designed for static layouts. Additional members of the HUB Division joined the effort, which evolved into the *HUB Modular Railroad Signal Committee* as we know it today.

At present, Dick Johannes is the Chairman, and the committee members are (in alphabetical order) Stan Ames, Ken Belovrac, Gerry Covino, Manny Escobar, Jeff Gerow, David "Shack" Haralambou, Mark Harlow, Bill Powers and Peter Watson.

The goal of the HUB's Signal Committee was to research, design and build a true modular signaling approach for the HUB's modular railroad. Signaling had previously been done on other modular railroads, but the solutions required a specific set of modules arranged in a specific order. This approach was not adequate for the HUB, due to the variety of layout shapes and sizes that we display at our shows each year. An additional complexity was the fact that the same set of modules are not always displayed together, because the combined total number of modules owned by modular group members is more than can be used in any one show. So our Module Coordinator routinely rotates through the available modules to ensure that all members have an opportunity to show their module(s) at least a couple times a year.



6/24/20



NMRA Photos



6/24/20



NMRA Photos

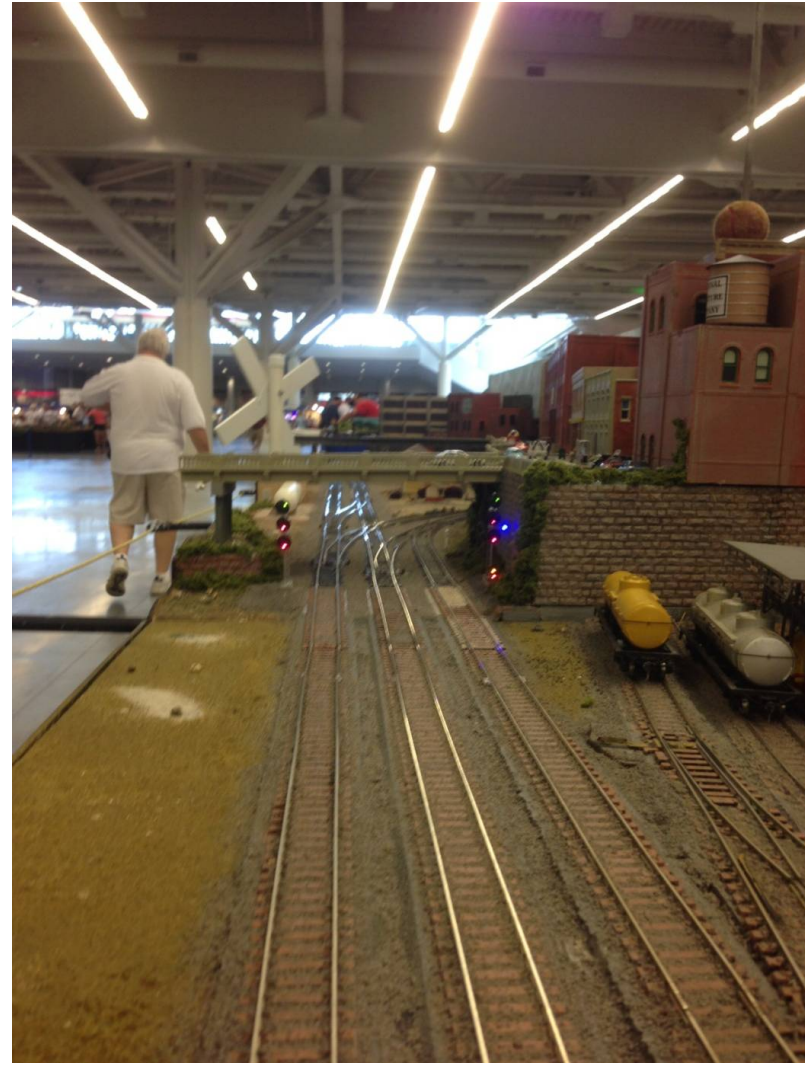

6/24/20



Section II



Where are we now?



Where are we now?

- Signaling is implemented as discussed in the prior slides
- There have been several usability and performance issues found at various train shows
- We need a way to divide, conquer and diagnose the system to improve reliability and usability
- There are several software improvements we are currently working with Rodney Black on. We've been meeting at the NMRA National conventions.



Section III



Introducing the HUB Modular Signaling Testbed



Introducing: The HUB Modular Signaling Testbed

- Goals:
 - Create a test setup that's easier to manage than a large layout
 - Create “passive” and “active” modules that act like the real modules
 - Test the interaction of block detectors, turnouts, and signals with JMRI, CMRI, and CATS (hardware and software)
 - Once the process is debugged, roll out to the actual layout
 - Design and test new software updates before going live at a show



HUB

Modular Signaling Testbed



- The HUB Module Standard requires a double-track main line
 - There's an optional third and fourth track
- Remember Dick's five initial test modules
- There's eight configurations that cover all of the turnout and signal configurations
 - The single-track configurations that follow represent the cases where additional tracks are added to the double main line standard and may or may not have signaling



Passive Single Track



Blocks: 0
Switch Position: 0
Signal Lines: 0
0 IN/0 OUT





Passive Double Track

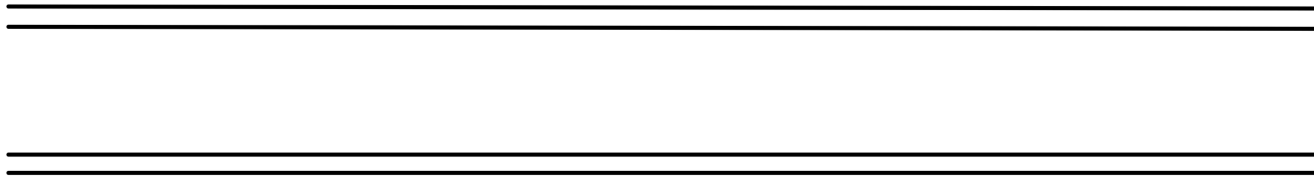

Blocks: 0
Switch Position: 0
Signal Lines: 0
0 IN/0 OUT





CTC Single Track

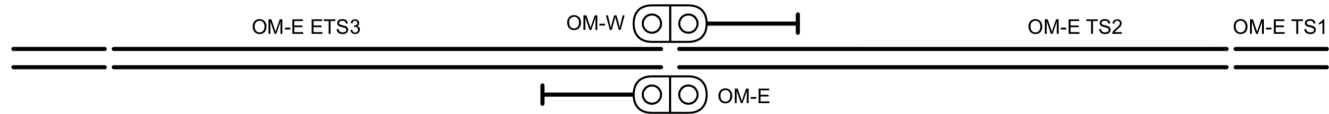

Blocks: 3
Switch Position: 0
Signal Lines: 12
2 IN/12 OUT

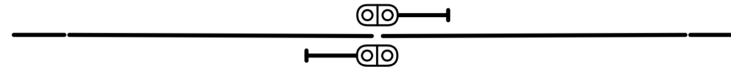



CTC Double Track

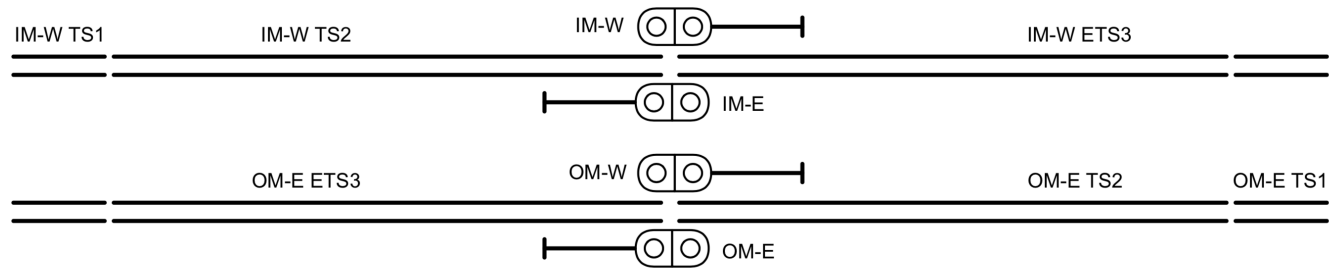

Blocks: 6
Switch Position: 0
Signal Lines: 24
4 IN/24 OUT

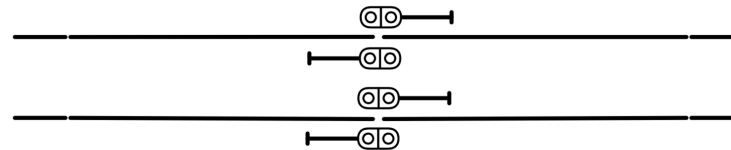



CTC OS Left

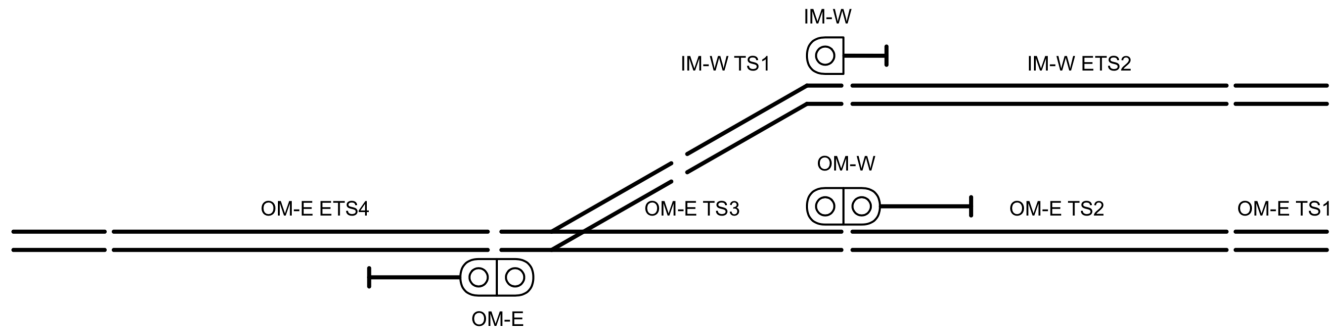

Blocks: 6
Switch Position: 2
Signal Lines: 15
6 IN/15 OUT
DCC Accessory Decoder: 572

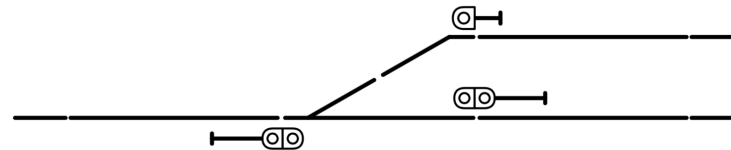



CTC OS Right

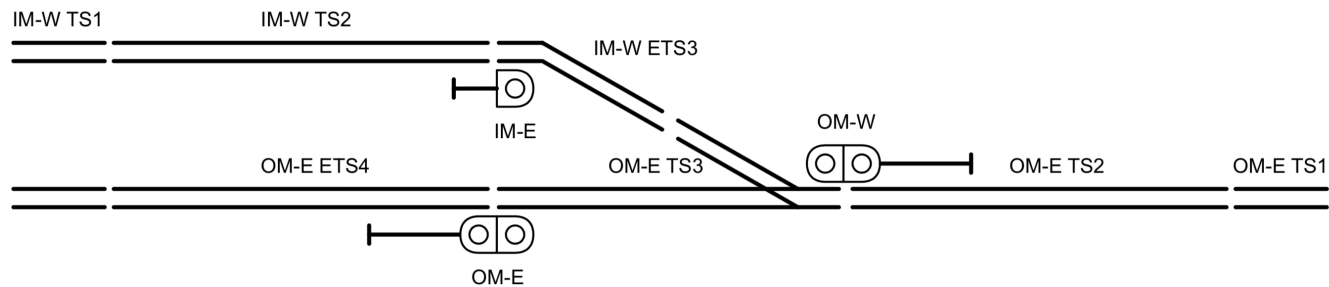

Blocks: 6
Switch Position: 2
Signal Lines: 15
6 IN/15 OUT
DCC Accessory Decoder: 573

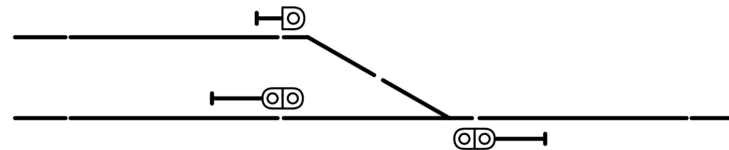



CTC Crossover Left

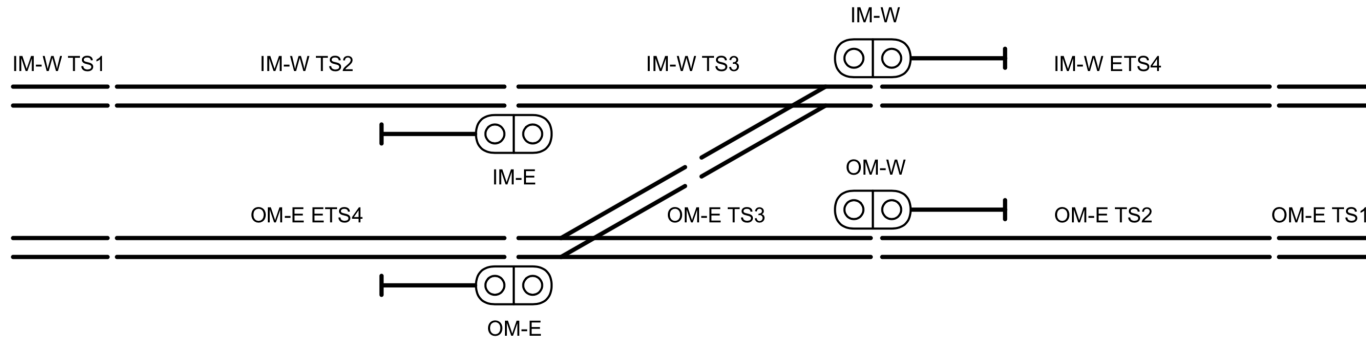

Blocks: 8
Switch Position: 2
Signal Lines: 24
8 IN/24 OUT
DCC Accessory Decoder: 570

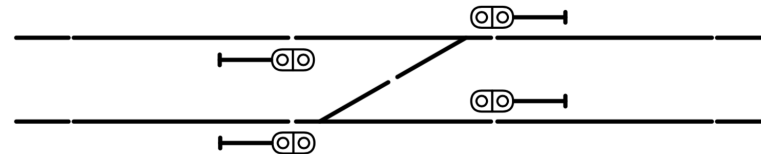



CTC Crossover Right

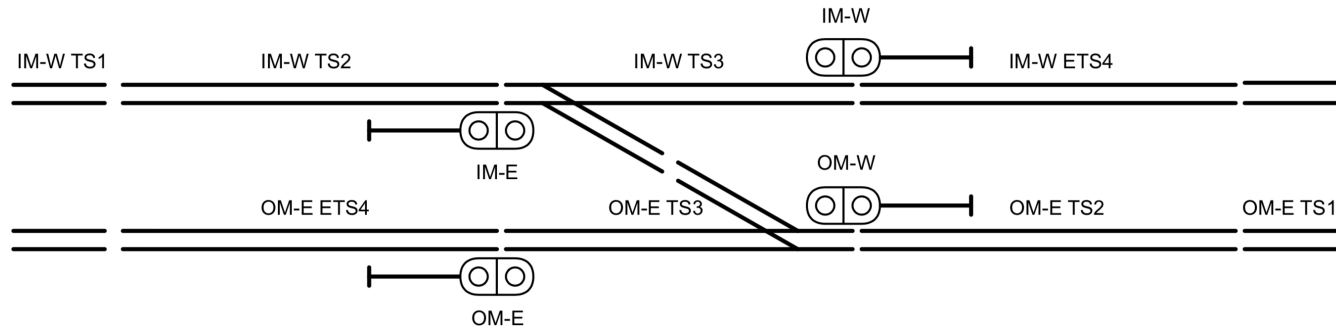

Blocks: 8
Switch Position: 2
Signal Lines: 24
8 IN/24 OUT
DCC Accessory Decoder: 571

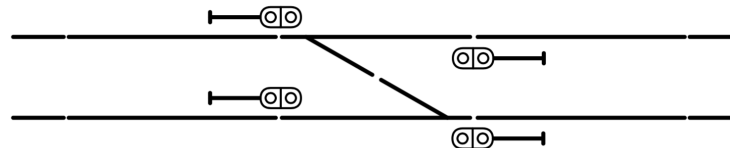



What about the hardware?



-
- The HUB Modular Signaling Testbed provides a way to experiment with module configurations that mimic the actual modules without setting up an entire layout
 - I designed a set of printed circuit boards (PCBs) to implement the hardware portion of the testbed
 - We use JMRI and CATS to connect to the testbed as though it were an actual layout



What about the hardware?



-
- Signals
 - Digital outputs drive the LEDs (we used MRCS signal heads)
 - cpNode/SMINI have enough drive to LEDs with a current-limiting resistor
 - Block Detection
 - Use pushbutton switches to drive the block occupancy cpNode/SMINI digital inputs
 - Use LEDs for visual feedback
 - Turnouts
 - Use pushbutton to manually control turnout position, also control from CATs via DCC
 - Use LEDs for feedback, send feedback to cpNode/SMINI
 - Use an actual Tortoise with a DCC Specialties Accessory Decoder



What about the hardware?



-
- The Testbed is made up of 2 printed circuit board (PCB) designs
 - Active Module: Represents 6 different active track configurations (with signals)
 - Single or Double Track CTC
 - Left or Right OS
 - Left or Right Crossover
 - Passive Module: Represents 8 different passive track configurations (no signals)
 - Single or Double Track Straight Section
 - Single or Double Track Left or Right Curve Section



Passive Test Module PCB

One PCB Layout works for all 8 passive configurations

2-layer PCB board

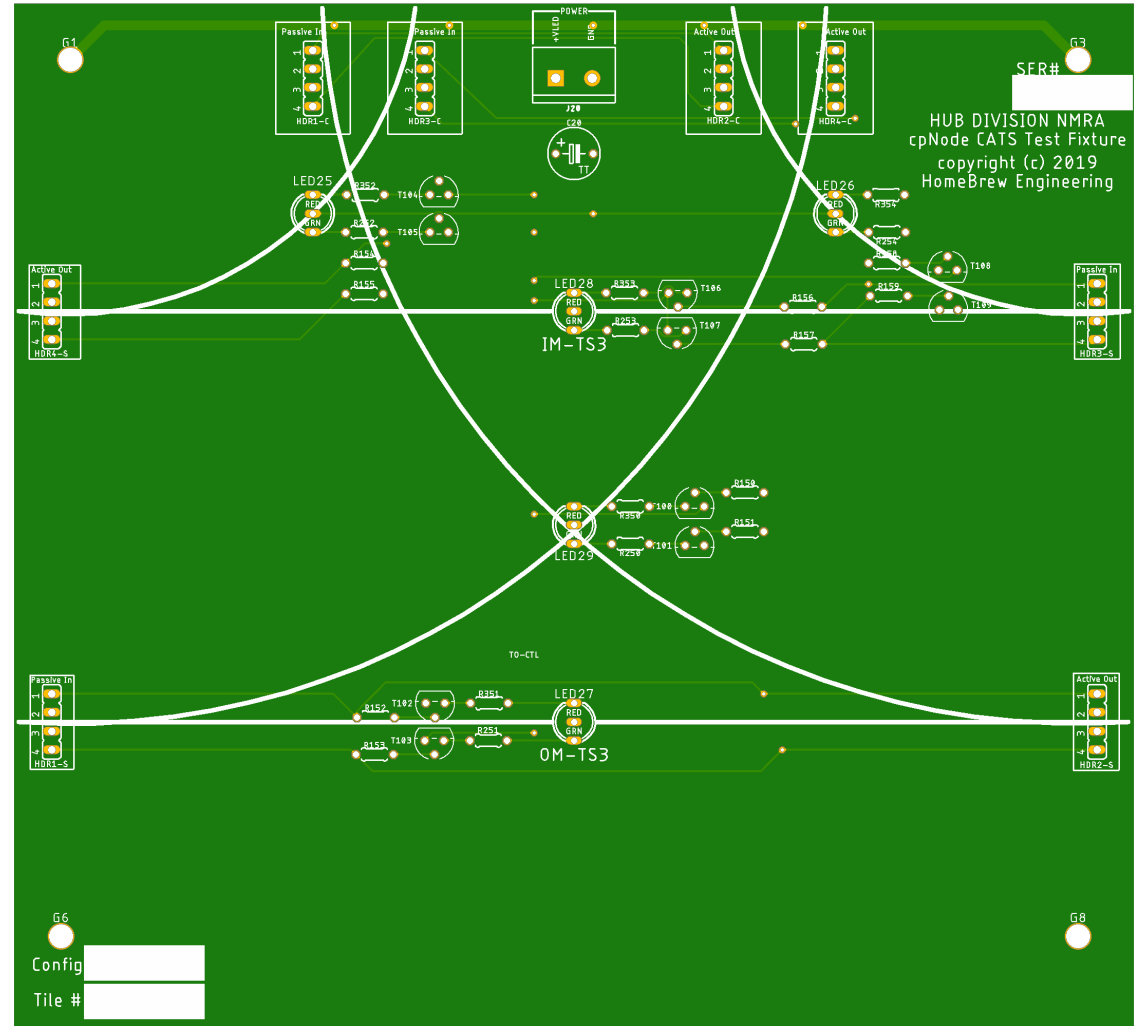



Active Test Module PCB

One PCB Layout works for all 6 active configurations

4-layer PCB board

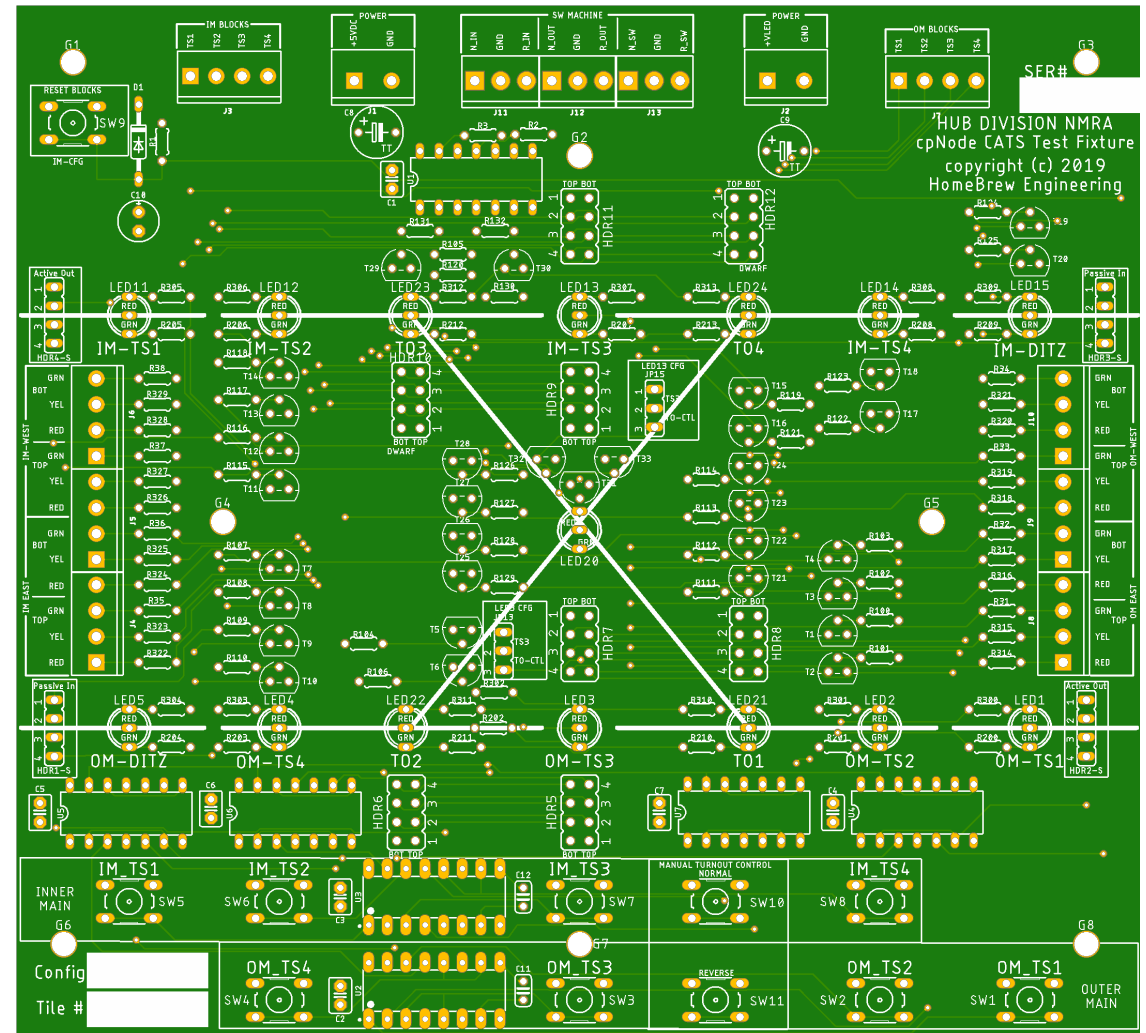



Test Layout Tiles

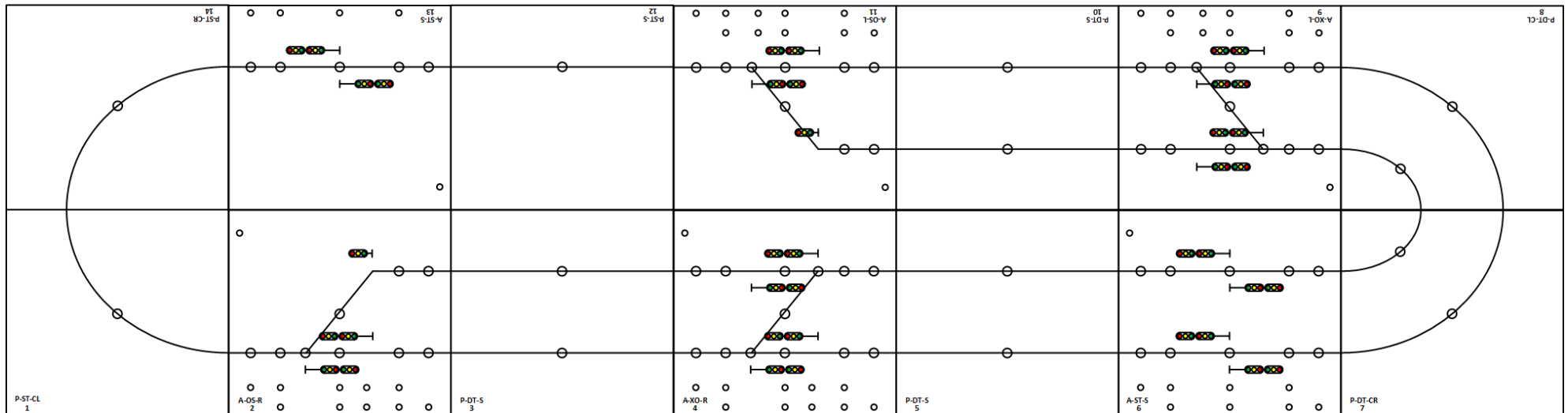



Testbed Module Design



- 4' long
- 18" wide
- 18" high
- Tiles mounted to Polycarbonate
- Front side represents the module top
- Back side represents the module bottom
- Easy to see what's going on without crawling under a module

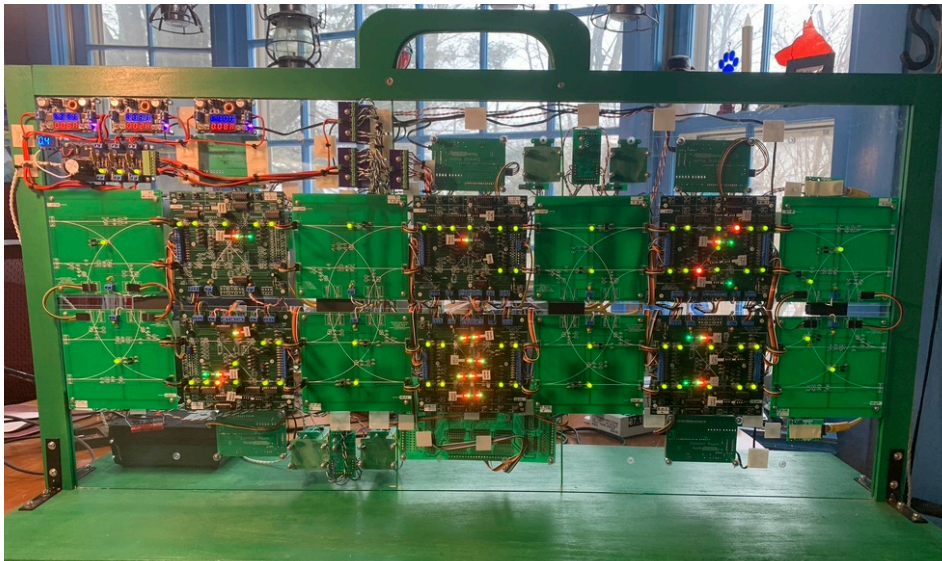
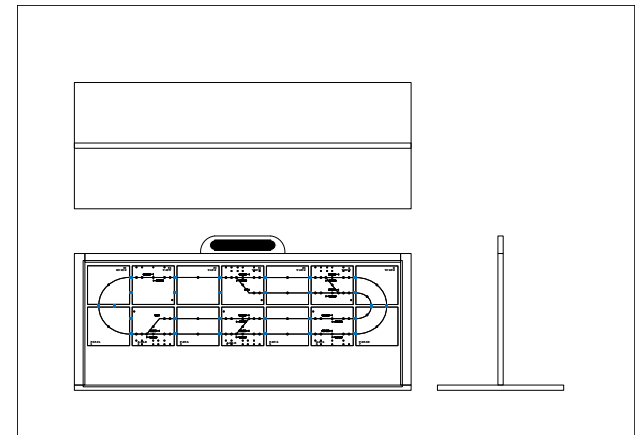

Front (top of modules)

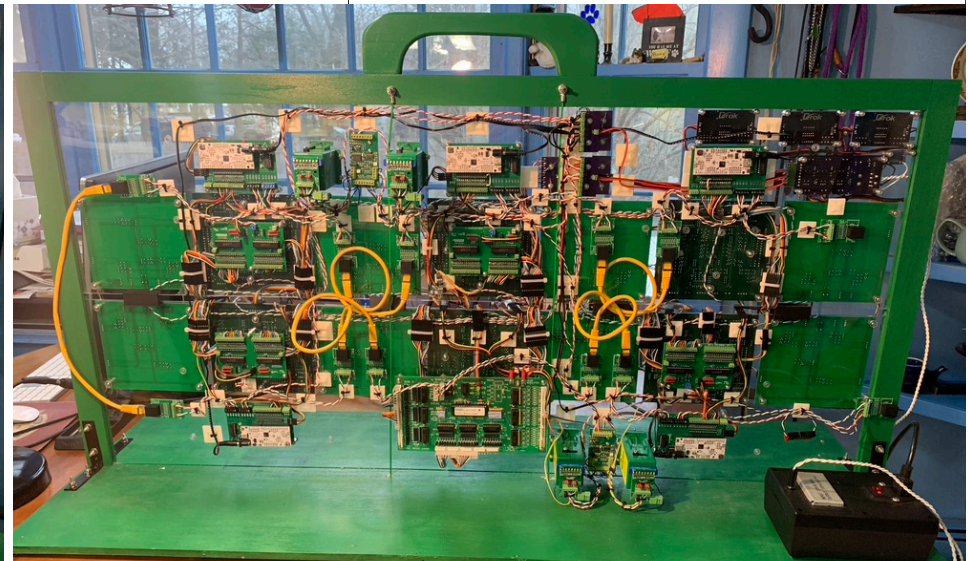

Back (bottom of modules)



Need to map the hardware to the software



-
- I used an Excel spreadsheet to map the I/Os needed
 - (This spreadsheet is an entire clinic in and of itself!)*
 - Use 1 node (either cpNode or SMINI) for each active module
 - 6 Active Modules => 6 CMRINet Nodes
 - 8 Passive Modules => Pass-through



Additional Hardware CMRINet Nodes



CMRI Node		Configuration	In	Out
Node 1	cpNode	BASE_NODE_12OUT4IN	4	12
	IOX	-	0	0
Node 2	cpNode	BASE_NODE_16IN	16	0
	IOX	IOX32_32OUT_0	0	32
Node 3	cpNode	BASE_NODE_16IN	16	0
	IOX	IOX32_32OUT_0	0	32
Node 4	cpNode	BASE_NODE_16IN	16	0
	IOX	IOX32_32OUT_0	0	32
Node 5	cpNode	BASE_NODE_16IN	16	0
	IOX	IOX32_32OUT_0	0	32
Node 6	SMINI	SMINI	24	48



Additional hardware (continued)



- Power Supply
 - 5V for SMINI and Logic Power
 - 6V for cpNodes
 - Adjustable LED power

*(see **HUB Headlight Volumes 35 #4 & #5**)*
- 4 Tortoise switch machines
- 2 DCC Specialties Wabbit decoders
- DCC Command Station (DCS)
 - Needed for the stationary decoders
 - DCS Host Interface for JMRI
- RS485 to USB adapter
 - Connects CMRI to the PC

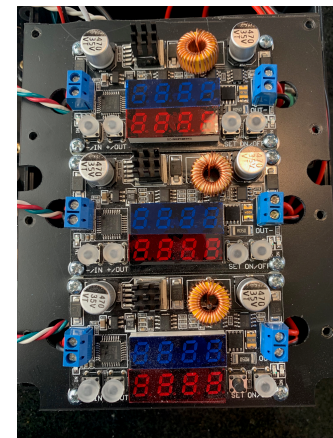
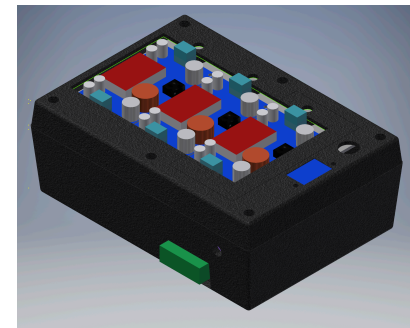



CATS Module Definitions



Passive Single Track

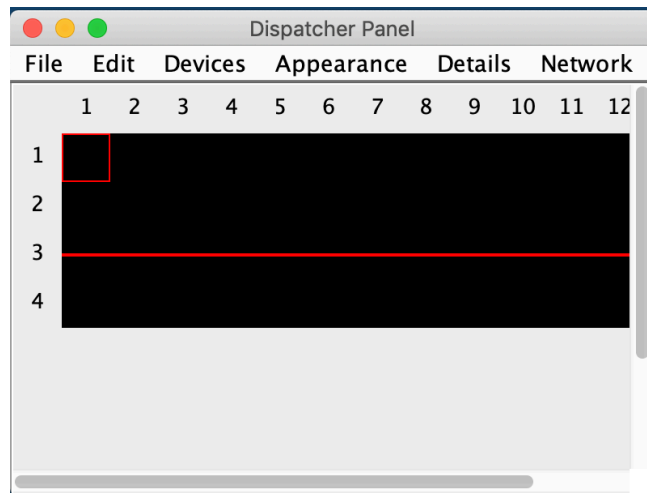

Passive Double Track

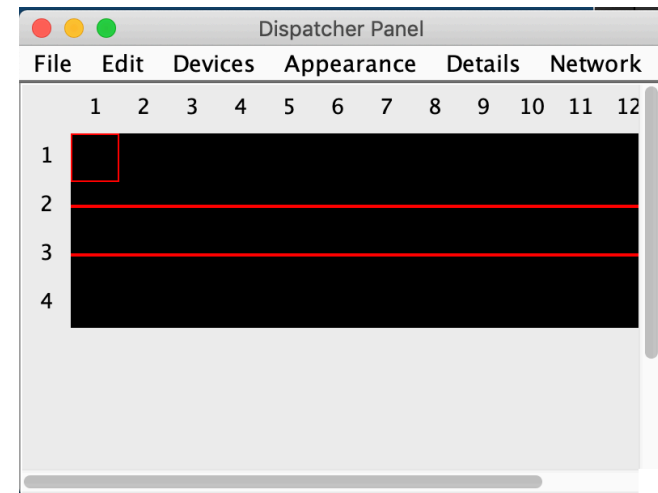



CATS Module Definitions



CTC Single Track

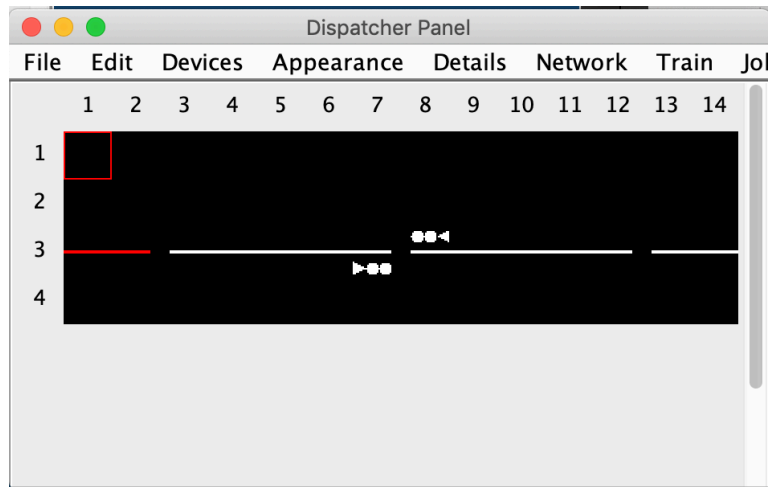

CTC Double Track

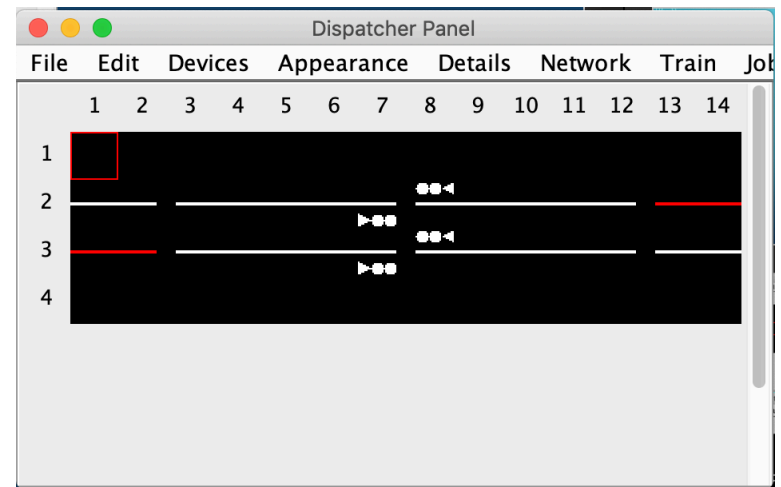



CATS module definitions



CTC OS Left

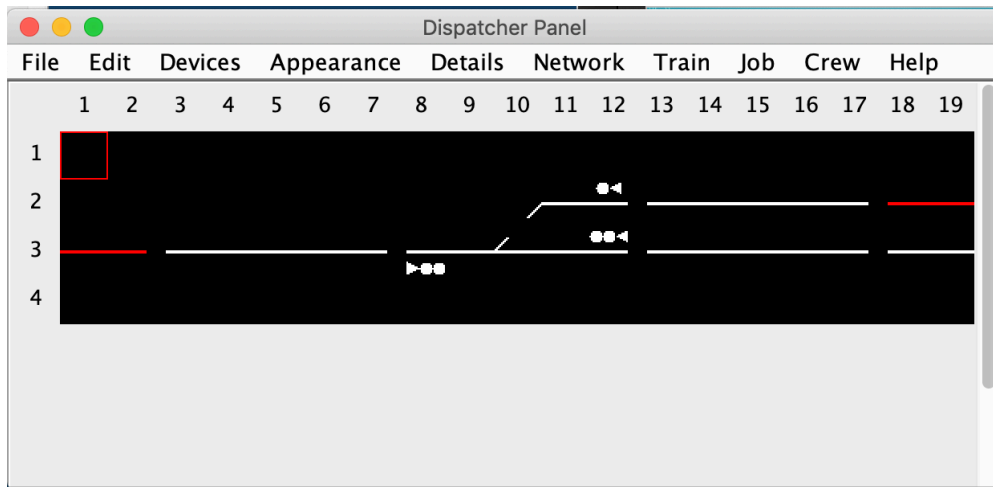

CTC OS Right

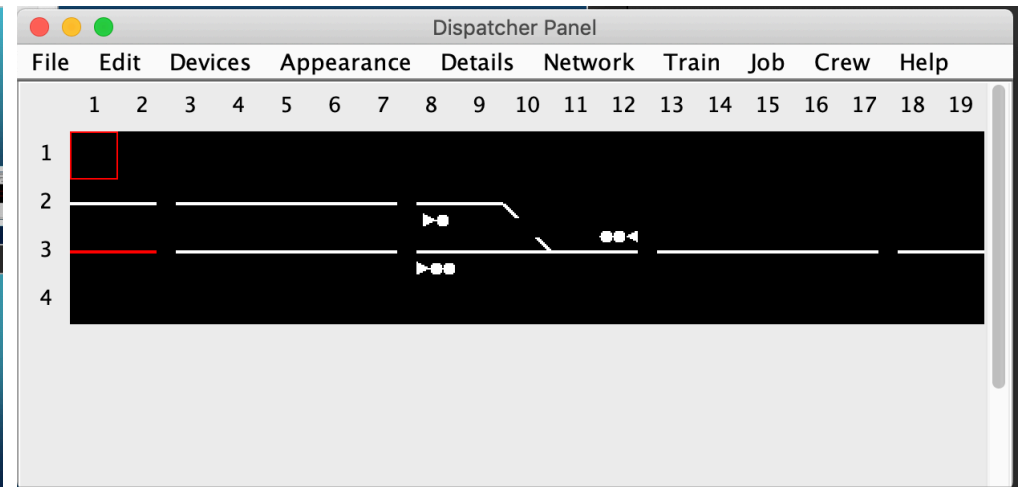



CATS module definitions



CTC Crossover Left

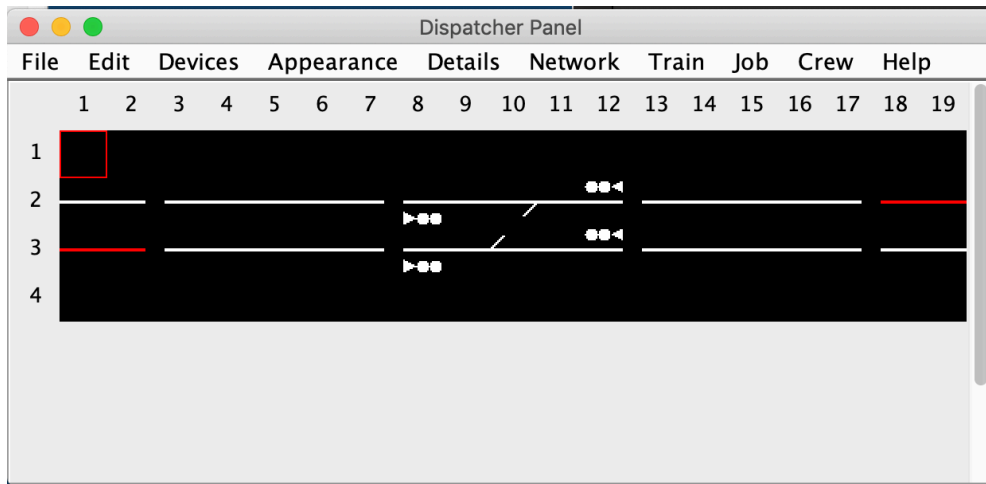

CTC Crossover Right

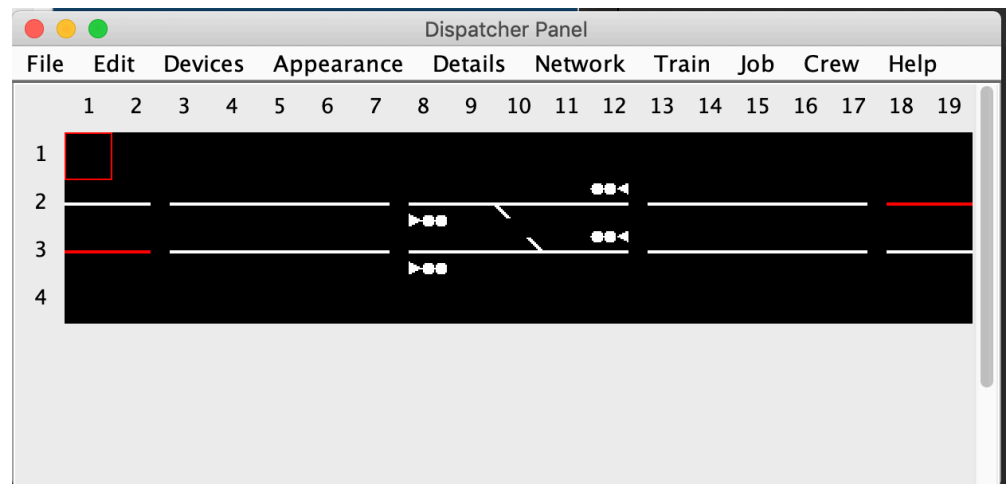



Testbed CATS definition



Putting it all together

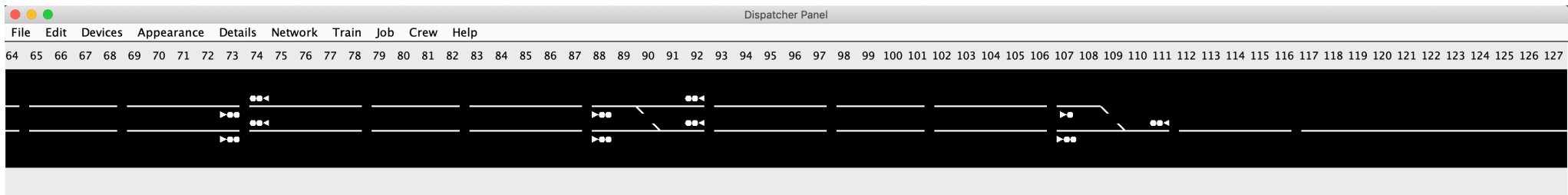
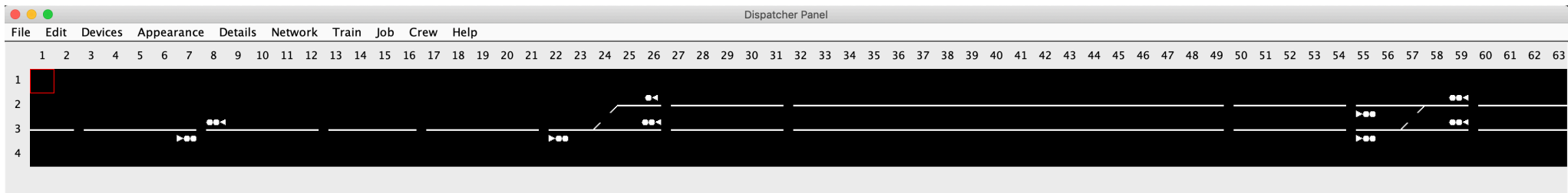



Testbed Summary

- Introduced the testbed
- Discussed the hardware and software
- What's Next?
 - Deep dive and live demonstration of the testbed
 - To be scheduled, preferably when we can get together.



Section IV



Discussion, Summary, and References



Discussion

- The testbed can also be used to test a module's signaling! (*I'm still working on this*)
- I would like to restart the signaling committee for active participation of interested members



Discussion



The HUB Module Specification is currently being updated and expanded!

- Updated CAD drawings
- Additional sections for signaling and corner module

HO Module Handbook



Fifth Edition – July 2020

	MODULAR LAYOUT SYSTEM SPECIFICATIONS HUB DIVISION NORTHEASTERN REGION, NMRA	DATA SHEET	HUB MS1-1	
		PAGE	2	OF 10
		REVISION	7	
		DATE	6/15/20	

Table of Contents

Introduction.....

Summary of Standards and Recommended Practices

General Electrical Specifications

Section 1: Straight Module.....

Parts list.....

Open top straight module

Full top straight module.....
 Open top straight module w/optional third track.....
 Full to straight module w/optional third track.....

Two track straight module

Three track straight module.....

Suggested method of assembly.....
 Suggested method of assembly, module w/local track.....
 Suggested method of assembly, two track module.....
 Suggested method of assembly, two track full top module.....
 Suggested method of assembly, full top module w/local track.....
 DCC connector box mounting.....

Section 2: Outside Corner Module.....

Section 3: Inside Corner Module.....

Section 4: Signaling.....

Section 6: Accessory DC Power.....

Legs and Leg Pockets.....

Registering your devices.....

Throttles.....

DCC accessory decoders.....

C/MRI nodes.....

	MODULAR LAYOUT SYSTEM SPECIFICATIONS HUB DIVISION NORTHEASTERN REGION, NMRA	DATA SHEET	HUB MS1-1	
		PAGE	31	OF 41
		REVISION	7	
		DATE	6/15/20	

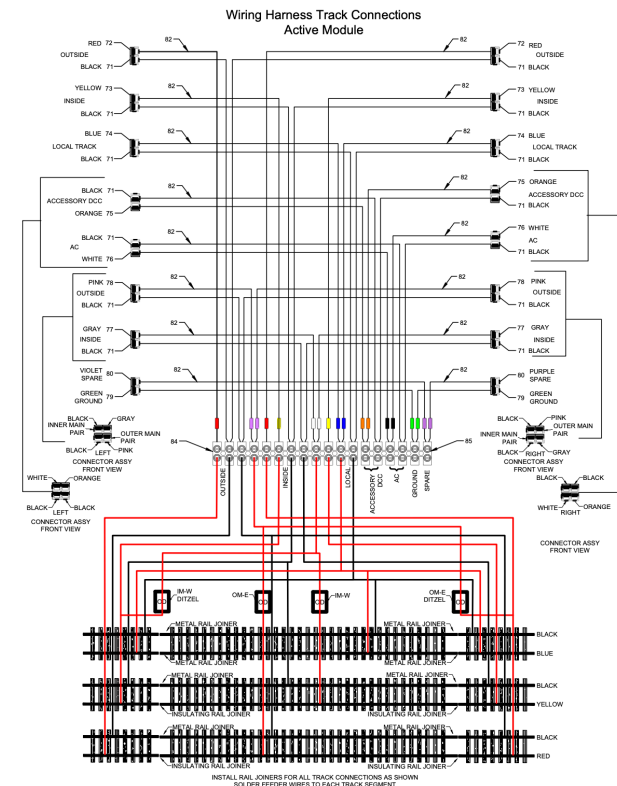



Discussion

- I have been developing a HUB Module Tester to easily and quickly verify that a module meets the standard prior to plugging in at a show





Discussion

- What about LCC?
 - LCC and CMRI coexist quite nicely through JMRI
 - You can use LCC on your modules today—just not for signaling on the main line
 - We don't currently have an LCC network on the modular layout, but one could easily be added with an additional CAT5/RJ45 connection
 - This is a great topic to discuss with the module group and I encourage it!



Conclusion



-
- Reviewed prior work on the HUB Modular Group Signaling System
 - Discussed the current status of the signaling system
 - Introduced the HUB Modular Signaling Testbed
 - Group Discussion



References (Books)

- *Railroad Signaling*. Brian Soloman, MBI Publishing 2003.
- *How to operate your model railroad*. Bruce A Chubb, 2nd Edition, Kalmbach, 1977.
- *Realistic Model Railroad Operation*. Tony Koester. Kalmbach 2003.
- *The Model Railroaders Guide to Junctions*. Jeff Wilson. Kalmbach 2006.
- *Railroader's C/MRI Applications Handbook V3.0* (Volumes 1,2,&3 Especially Vol 2). Bruce Chubb. Available through JLC Enterprises.
- *Railroad Operation and Railway Signaling*. Edmund J Phillips. Simmons-Boardman 1942
- *Compendium of Signals*. Roger F.R Karl. Boynton, 1971.
- *All About Signals*. John Armstrong, Kalmbach, 1967.
- *34 New Electronic Projects for Model Railroaders*. Peter J Thorne, Kalmbach, 1982.



References (Journals)

- **Operating signals with software.** *Model Railroader*, October 2007, page 50.
- **The Computer/Model Railroad Interface - A Case Study.** *Model Railroading*, December 1999/January 2000, page 32.
- **Using State-of-the-art Electronics to Enhance Operation.** *NMRA Bulletin*, March 2007 page 38.
- **Where to place trackside signals.** *Model Railroader*, October 2007, page 52.
- **Signaling made easier** (3-part article). *Model Railroader*, January 2004, page 130.
- **Absolute-Permissive Block Signals** (3 part article). *Model Railroader*, November 1991 page 128.
- **Centralized traffic control for the Cat Mountain Line.** *Model Railroader*, May 1984, page 74.



References (Web Sites)

- Carsten Lundstens site: http://www.lundsten.dk/us_signaling/index.html
- Norac Simulator: <http://raildata.railfan.net/java/DivRte/NORAC.htm>
- Railroad Signals: <http://www.railroadsignals.net/>
- Railroad Signals of the US: <http://www.railroadsignals.us/>
- JMRI: <https://www.jmri.org/>
- CATS: <http://cats4ctc.wikidot.com>
- CMRI: <http://www.jlcenterprises.net/>
- MRCS: <http://www.modelrailroadcontrolsystems.com/>
- Custom Signals (business being sold): <http://www.customsignals.com/>
- ISS: <http://www.integratedsignalsystems.com/>
- Signals by Spreadsheet: <http://www.signalsbyspreadsheet.com/>
- Railroad Circuits: <http://rr-cirkits.com/>
- Logic Rail: <http://www.logicrailtech.com/>



THANK YOU!

erich@hbeng.com